



Circuit Design Training Manual: Low Noise Amplifier Part II



ANSYS, Inc.
Southpointe
2600 Ansys Drive
Canonsburg, PA 15317
ansysinfo@ansys.com
<https://www.ansys.com>
(T) 724-746-3304
(F) 724-514-9494

Release 2024 R2
July 2024

ANSYS, Inc. and
ANSYS Europe,
Ltd. are UL
registered ISO
9001:2015
companies.

Copyright and Trademark Information

© 1986-2024 ANSYS, Inc. Unauthorized use, distribution or duplication is prohibited.

ANSYS, Ansys Workbench, AUTODYN, CFX, FLUENT and any and all ANSYS, Inc. brand, product, service and feature names, logos and slogans are registered trademarks or trademarks of ANSYS, Inc. or its subsidiaries located in the United States or other countries. ICEM CFD is a trademark used by ANSYS, Inc. under license. All other brand, product, service and feature names or trademarks are the property of their respective owners. FLEXlm and FLEXnet are trademarks of Flexera Software LLC.

Disclaimer Notice

THIS ANSYS SOFTWARE PRODUCT AND PROGRAM DOCUMENTATION INCLUDE TRADE SECRETS AND ARE CONFIDENTIAL AND PROPRIETARY PRODUCTS OF ANSYS, INC., ITS SUBSIDIARIES, OR LICENSORS. The software products and documentation are furnished by ANSYS, Inc., its subsidiaries, or affiliates under a software license agreement that contains provisions concerning non-disclosure, copying, length and nature of use, compliance with exporting laws, warranties, disclaimers, limitations of liability, and remedies, and other provisions. The software products and documentation may be used, disclosed, transferred, or copied only in accordance with the terms and conditions of that software license agreement.

ANSYS, Inc. and ANSYS Europe, Ltd. are UL registered ISO 9001: 2015 companies.

U.S. Government Rights

For U.S. Government users, except as specifically granted by the ANSYS, Inc. software license agreement, the use, duplication, or disclosure by the United States Government is subject to restrictions stated in the ANSYS, Inc. software license agreement and FAR 12.212 (for non-DOD licenses).

Third-Party Software

See the legal information in the product help files for the complete Legal Notice for Ansys proprietary software and third-party software. If the Legal Notice is inaccessible, please contact ANSYS, Inc.

Conventions Used in this Guide

Please take a moment to review how instructions and other useful information are presented in this documentation.

- Procedures are presented as numbered lists. A single bullet indicates that the procedure has only one step.
- Bold type is used in the following circumstances:
 - Keyboard entries that should be typed in their entirety exactly as shown. For example, “**copy file1**” means you must type the word **copy**, then type a space, then type **file1**.
 - On-screen prompts and messages, names of options and text fields, and menu commands. Menu commands are often separated by greater than signs (>). For example, “click **HFSS > Excitations > Assign > Wave Port.**”
 - Labeled keys on the computer keyboard. For example, “Press **Enter**” means to press the key labeled **Enter**.
- Italic type is used in the following circumstances:
 - Emphasis.
 - The titles of publications.
 - Keyboard entries when a name or a variable must be typed in place of the words in italics. For example, “**copyfilename**” means you must type the word **copy**, then type a space, then type the name of the file.
- The plus sign (+) is used between keyboard keys to indicate that you should press the keys at the same time. For example, “Press **Shift+F1**” means to press the **Shift** key and, while holding it down, press the **F1** key also. You should always depress the modifier key or keys first (e.g., **Shift**, **Ctrl**, **Alt**, or **Ctrl+Shift**), continue to hold it/them down, then press the last key in the instruction.

Accessing Commands: *Ribbons*, *menu bars*, and *shortcut menus* are three methods that can be used to see what commands are available in the application.

- The *Ribbon* occupies the rectangular area at the top of the application window and contains multiple tabs. Each tab has relevant commands that are organized, grouped, and labeled. An example of a typical user interaction is as follows:

"Click **Schematic > Ground** "

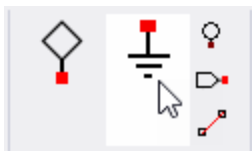

This instruction means that you should click the **Ground** command on the **Schematic** ribbon tab. An image of the command icon, or a partial view of the ribbon, is often included with the instruction.

- The *menu bar* (located above the ribbon) is a group of the main commands of an application arranged by category such File, Edit, View, Project, etc. An example of a typical user interaction is as follows:

"From the **File** menu, select the **Open Examples** command" means click the **File** menu, then click **Open Examples** to open an explorer window to the **Examples** folder.

- Another alternative is to use the *shortcut menu* that appears when you right-click. An example of a typical user interaction is as follows:

"Right-click and select **Assign Excitation > Wave Port**" means select an object, right-click, and click an option on the shortcut menu that appears.

Getting Help: Ansys Technical Support

For information about Ansys Technical Support, go to the Ansys corporate Support website, <http://www.ansys.com/Support>. You can also contact your Ansys account manager in order to obtain this information.

All Ansys software files are ASCII text and can be sent conveniently by e-mail. When reporting difficulties, it is extremely helpful to include very specific information about what steps are taken or what stages the simulation reached, including software files as applicable. This allows more rapid and effective debugging.

Help Menu

To access help on the Help menu, select **Help**. Then choose one of the following:

- **[product name] Help** - opens the contents of the help. This help includes the help for the product and its *Getting Started Guides*.
- **[product name] Scripting Help** - opens the contents of the *Scripting Guide*.
- **[product name] Getting Started Guides** - opens a topic that contains links to Getting Started Guides in the help system.

Context-Sensitive Help

To access help on the user interface, press **F1** to open the appropriate help for the active product (design type).

You can press **F1** while the cursor is pointing at a menu command or while a particular window tab is open. In this case, the help page associated with the command or open window is displayed automatically.

Table of Contents

Table of Contents	Contents-1
1 - Introduction	1-1
Prerequisite	1-1
Ansys Electronics Desktop	1-1
Enable Legacy View	1-3
2 - DC Analysis	2-1
Set up DC Analysis	2-1
Run DC Analysis & Plot DC-IV Curve	2-4
3 - LNA with Non-Linear Model	3-1
View DC Bias	3-1
Run Linear Analysis	3-3
Create Report	3-4
RF 1 Tone Nonlinear Analysis	3-6
Define RF 1 Tone Analysis	3-10
Define a Power Sweep and Analyze	3-11
Create Results: Pout/TG21 vs. Pin	3-13
Create Results: Spectrum	3-15
Create Results: Wave Form	3-15
Add a Second RF Source to Input port	3-16
Add Intermodulation Analysis Setup and Analyze	3-17
Create Results: Pout vs Pin	3-19
Create Results: Calculate IP3	3-20
Create Results: Intermodulation Spectrum	3-21
Harmonic Balance: Setup and Options	3-21

1 - Introduction

This document covers the following topics:

- Circuit Simulation
- Schematic Capture
- DC Analysis
- Linear (S-parameter) Analysis
- Nonlinear Analysis
- Single Tone
- Compression
- Multi Tone
- Intermodulation

Prerequisite

To perform the training exercise, you need the relevant designs and the corresponding footprints available at the following location: **Examples>Circuit>Low Noise Amplifier**.

Ansys Electronics Desktop

The Ansys Electronics Desktop, illustrated in the following figure, provides a comprehensive environment for designing and simulating various electronic components and devices.

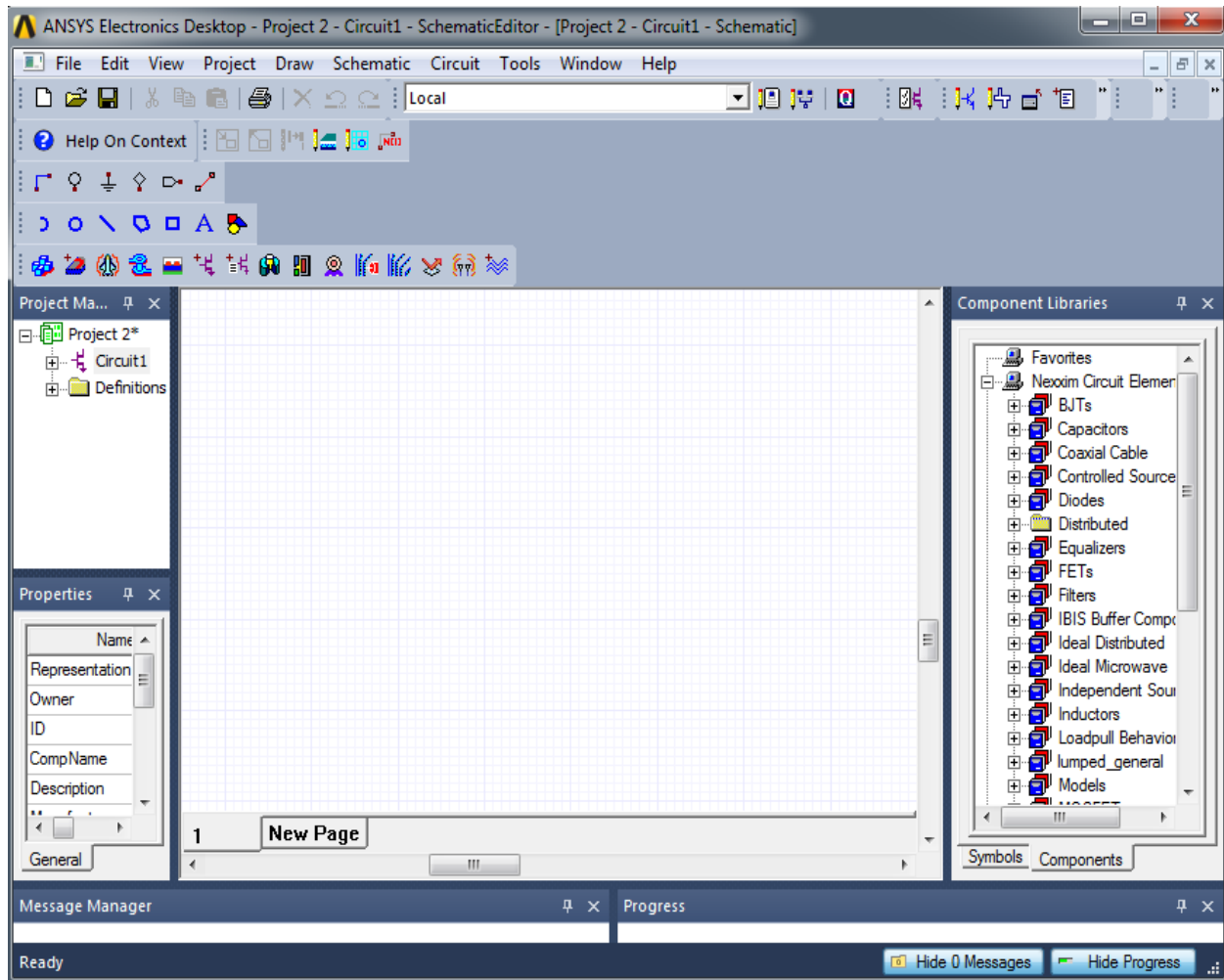

Figure 1-1 ANSYS Electronics Desktop

The desktop supports many design types. All design types appear as icons on the toolbar and under the **Project** menu. For simulating Low Noise Amplifier using an S-parameter model of NEC NE68133 BJT, select **Circuit Design**.

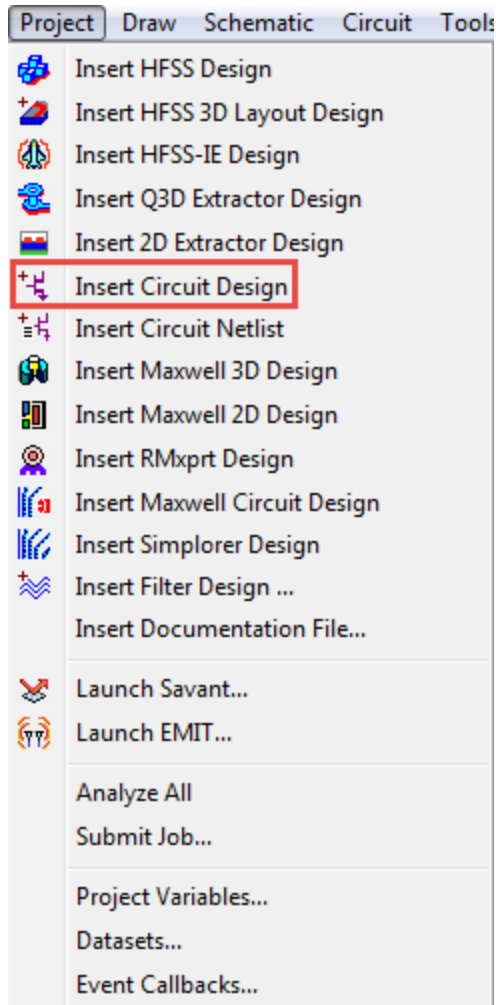

Figure 1-2 Project menu

Enable Legacy View

To view orientations consistent with the instructions and images in the guide, enable legacy view navigation.

1. Go to **Tools > Options > General Options**.
2. From the **Options** window, expand **General** and select **User Interface**.

3. Check **Enable Legacy View Navigation**

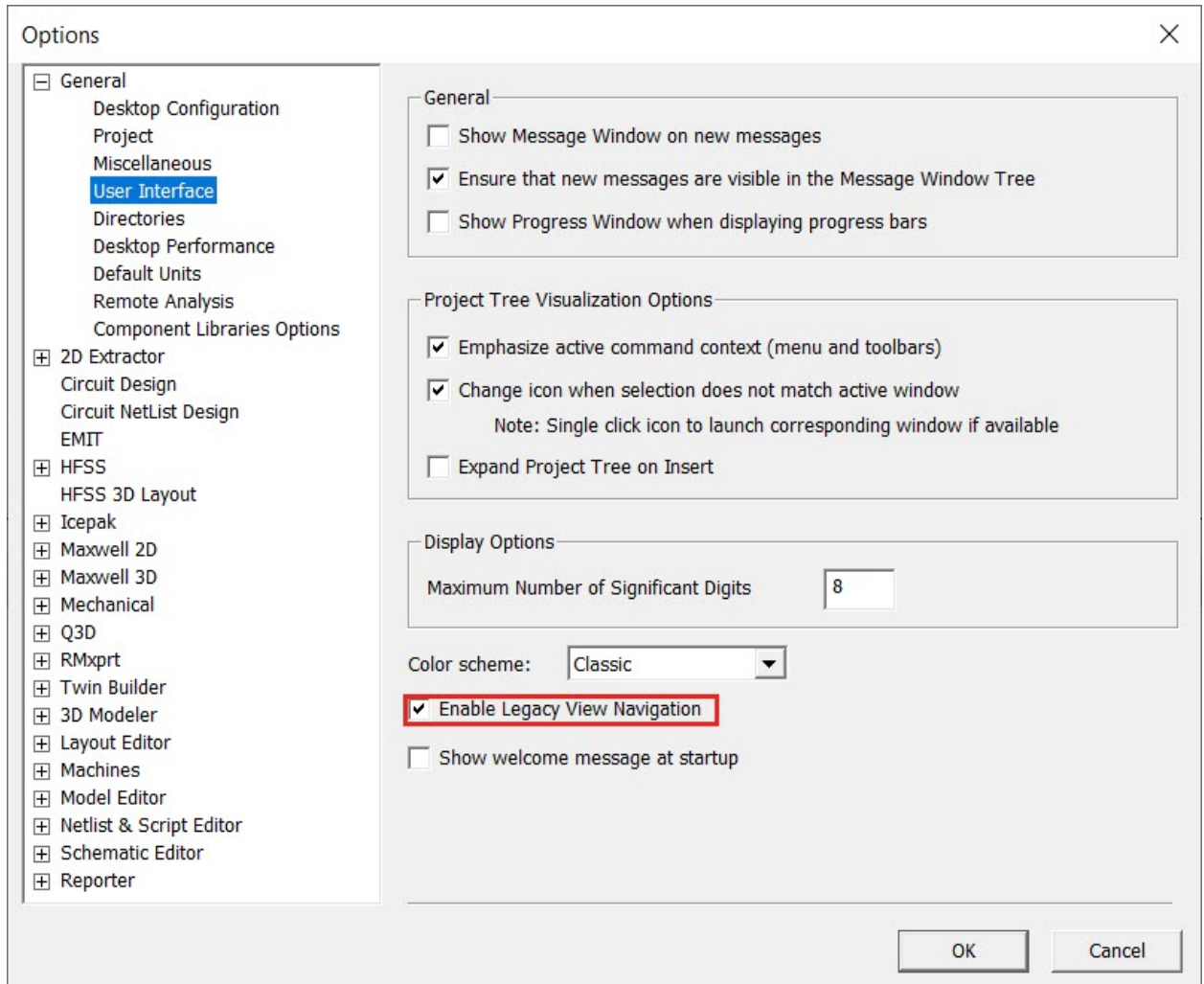

2 - DC Analysis

This section shows how to set up the Low Noise Amplifier schematic and define a DC analysis before running the simulation. Set up the schematic as follows:

1. Go to **File > Open Examples > Circuit > Low Noise Amplifier** and select *LNA_DC_IV_Start.aedt*.
2. Save the file in a different location other than the Examples folder.

The Low Noise Amplifier schematic of the inserted design has the circuit shown in the following figure. The circuit uses a non-linear model for the transistor (using a SPICE library file instead of the S-parameter data file).

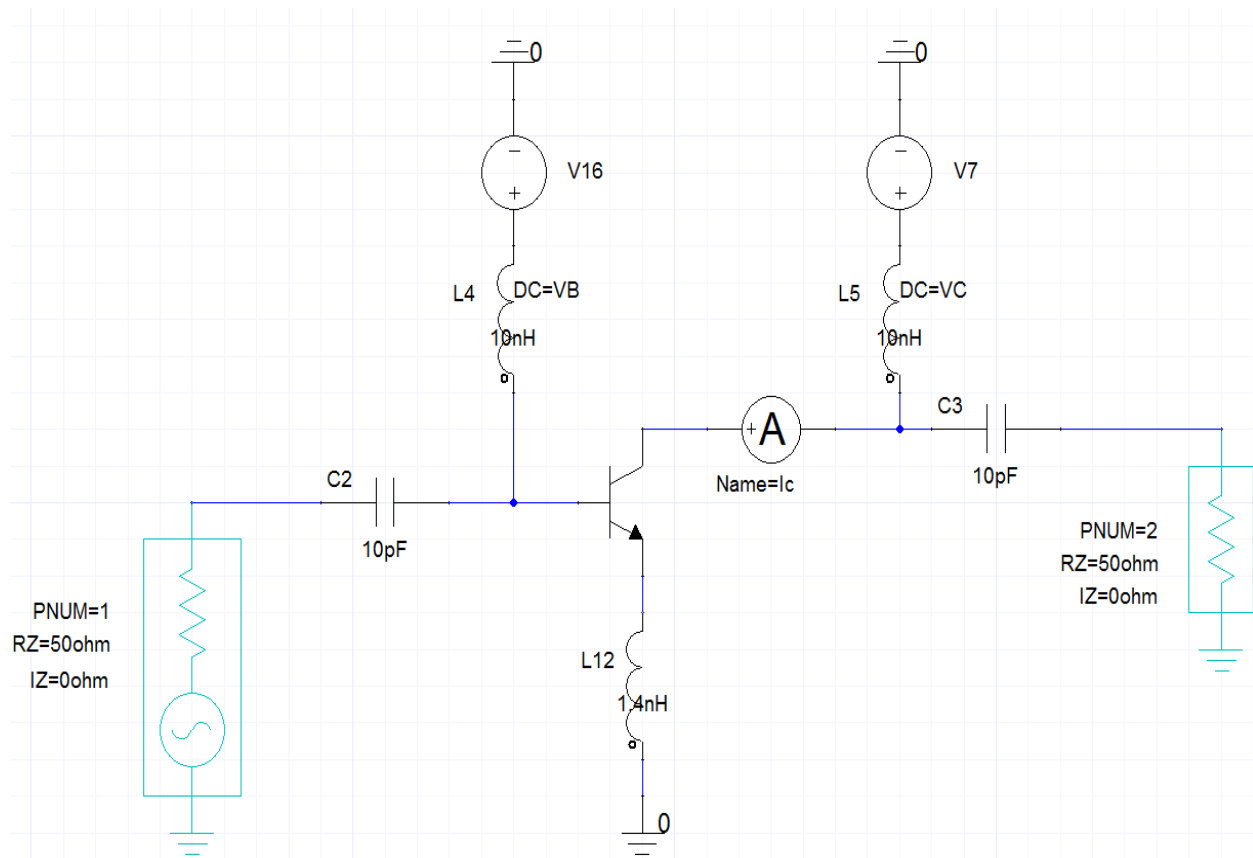
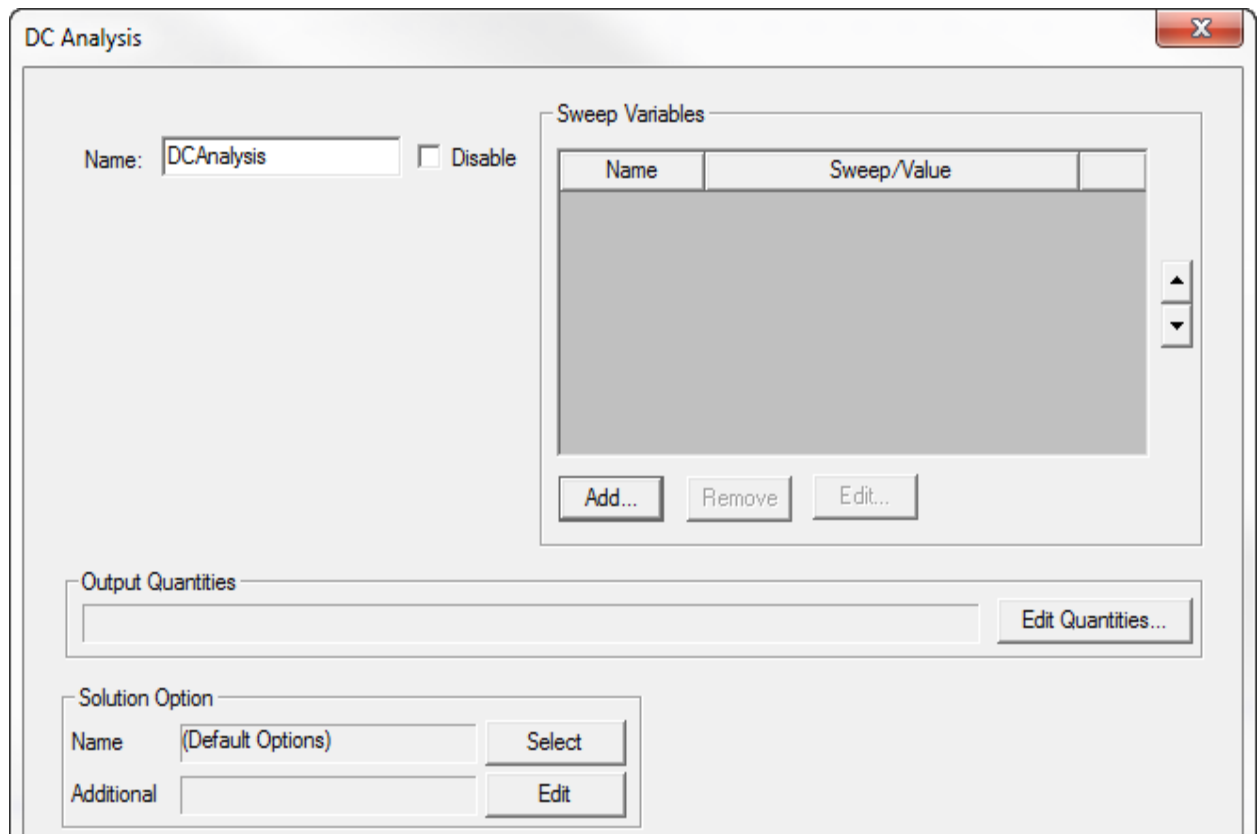
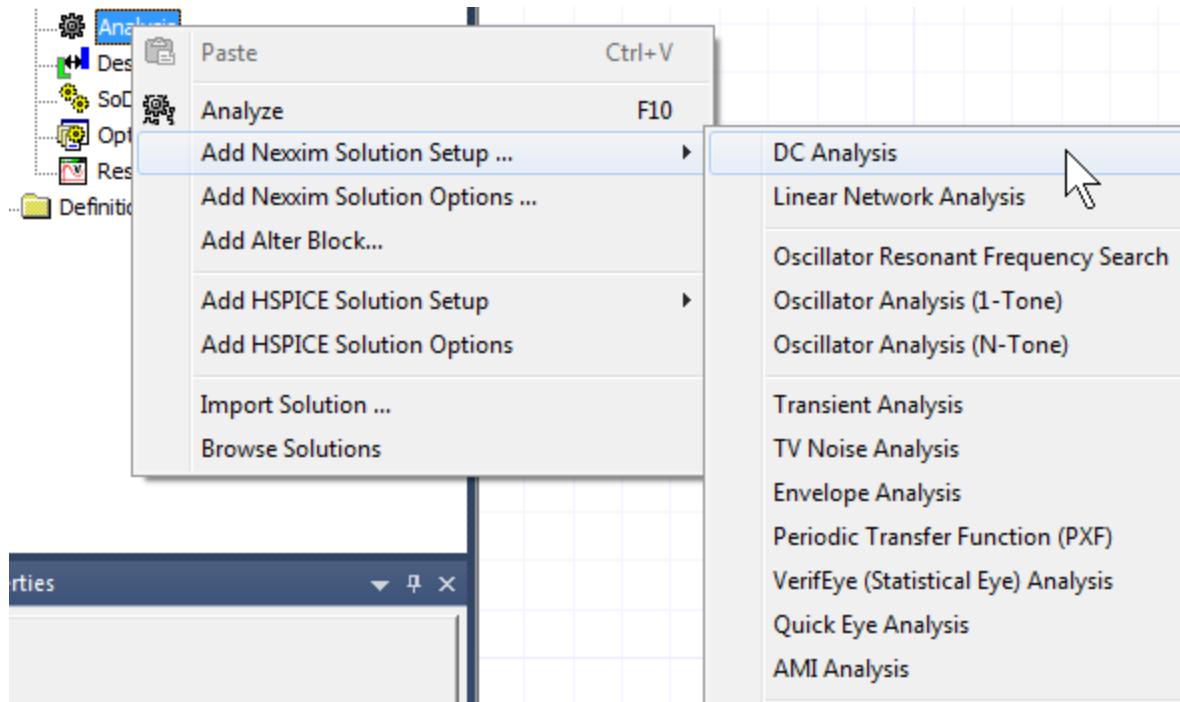

Figure 2-1 Circuit

Set up DC Analysis

1. From the **Project Manager** window, expand the **Project Tree** and active design folder. Then right-click **Analysis** and select **Add Nexxim Solution Setup > DC Analysis** to

open the **DC Analysis** window.



- Click **Add** on the **DC Analysis** window.
- From the window, click variable VB and define a **Linear step** sweep 0.75 to 0.85 with step 0.01 and click **OK**.

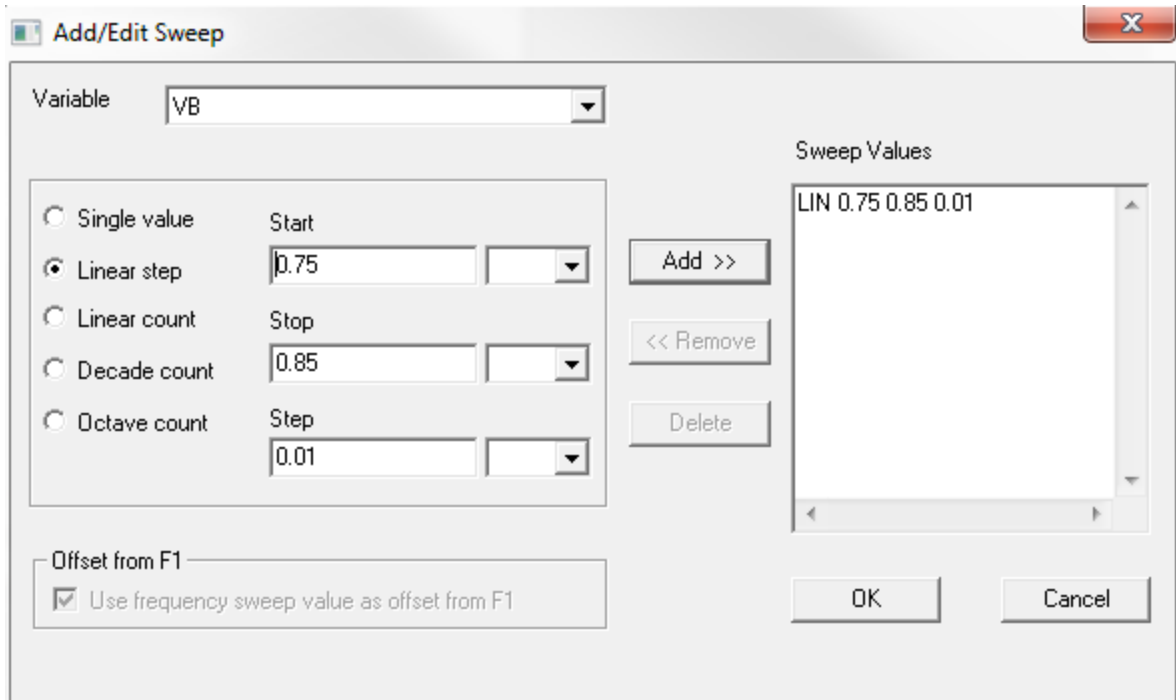

- Select **VC** and define two **Linear step** sweeps: 0 to 0.5 step 0.01, click **Add** ; then 0.5 to 5 step 0.5, click **Add**, then click **OK** .

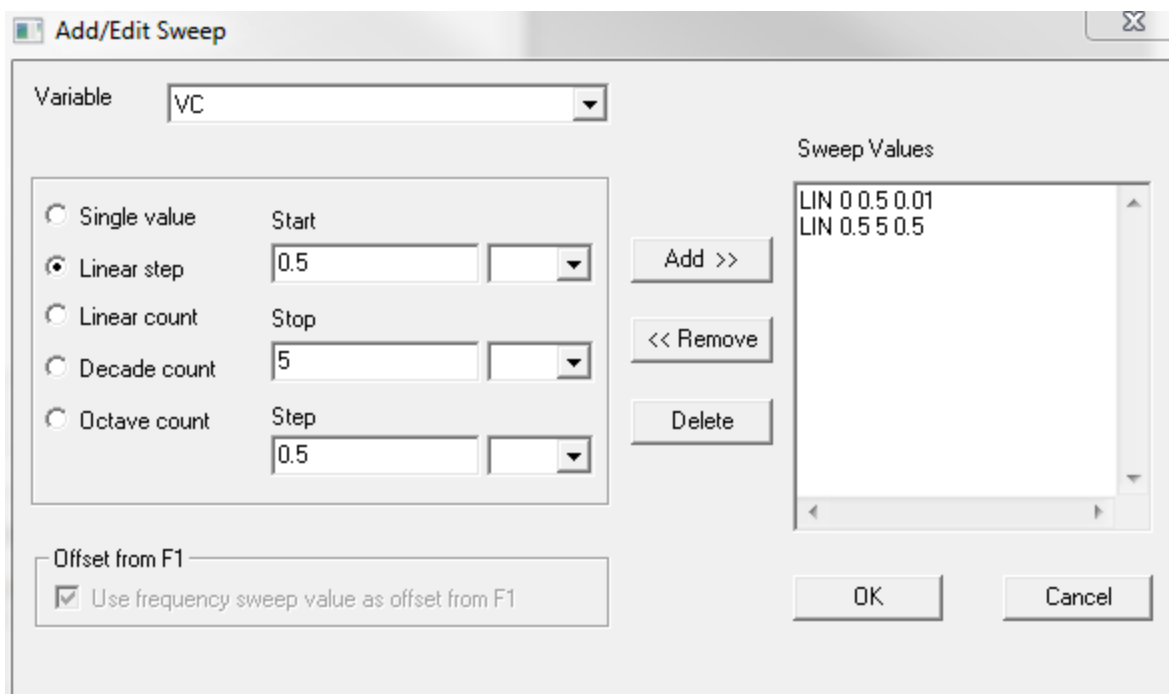

5. From the **Add/Edit Sweep** window, click **OK** to accept the settings.

Run DC Analysis & Plot DC-IV Curve

1. From the **Project Manager** window, expand the **Project Tree** and active design folder. Then right-click **DC Analysis** and select **Analyze**.
2. Right-click **Results** and select **Create Standard Report > Rectangular Plot**.
3. Select **VC** on the Primary Sweep, **Current** under Category and **Inegative(Ic)** under Quantity as shown in the following figure.

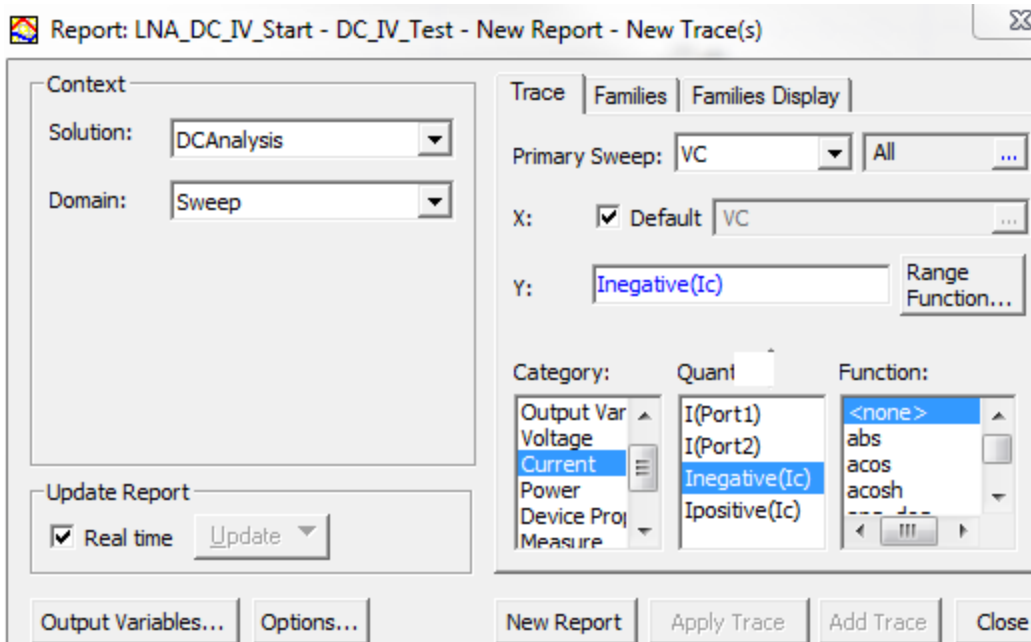

- From the **Families** tab, click the ellipsis under **Edit** and select **All** value for **VB**.

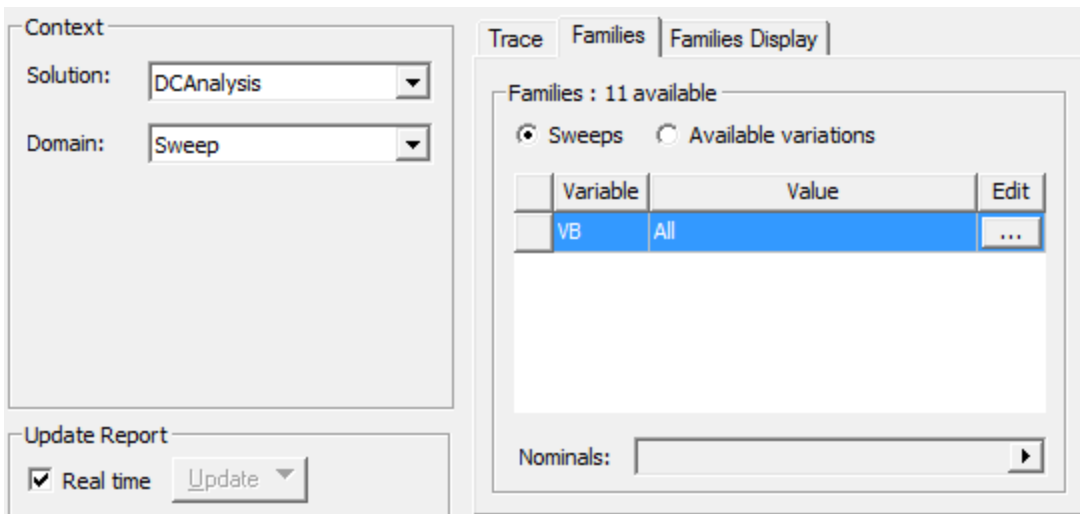

- Click **New Report** and **Close**.

DCIV Curves are generated as shown in the following figure.

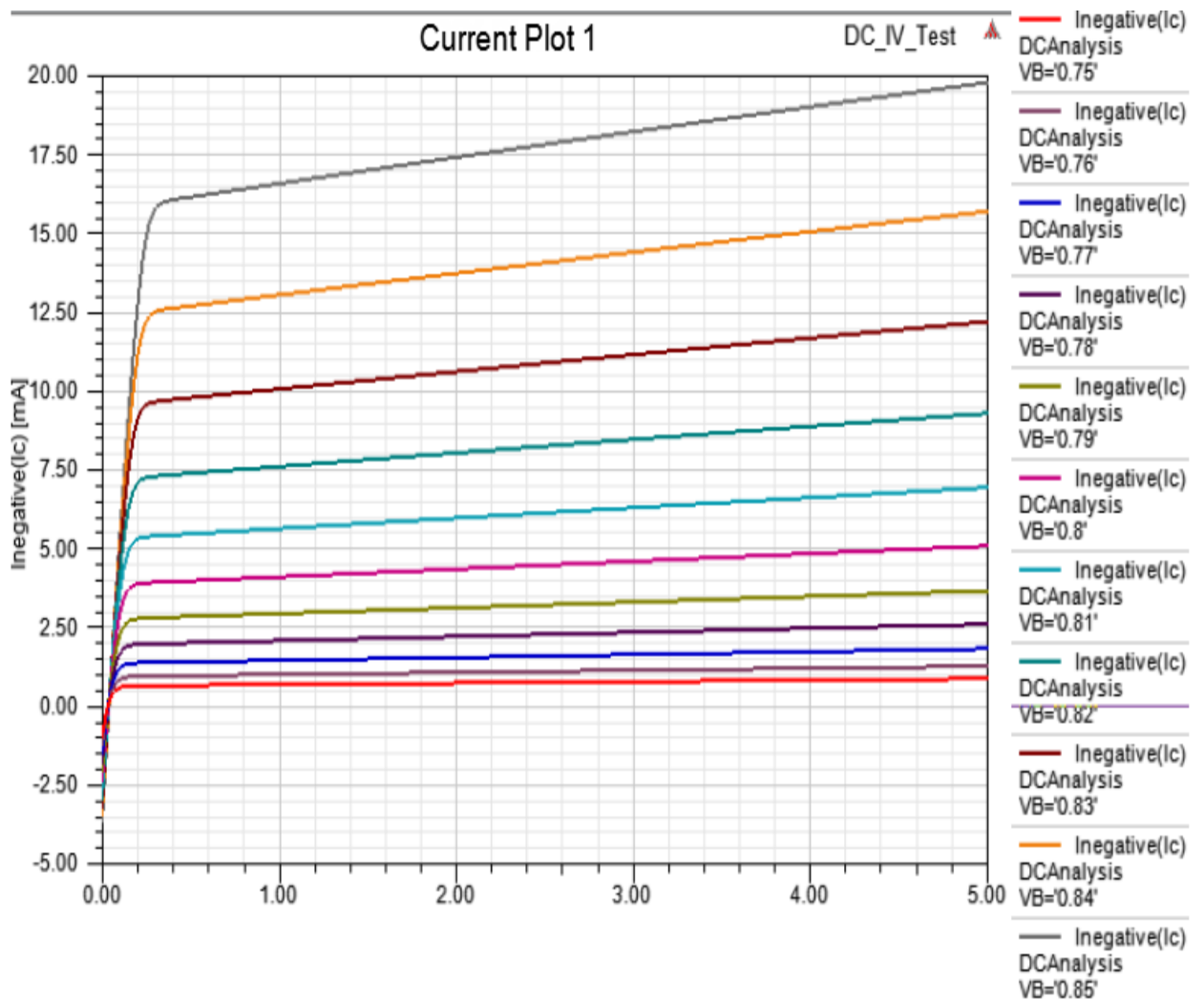

Note: If you just want the value for current probes, check DC Display options as shown in the following figure.

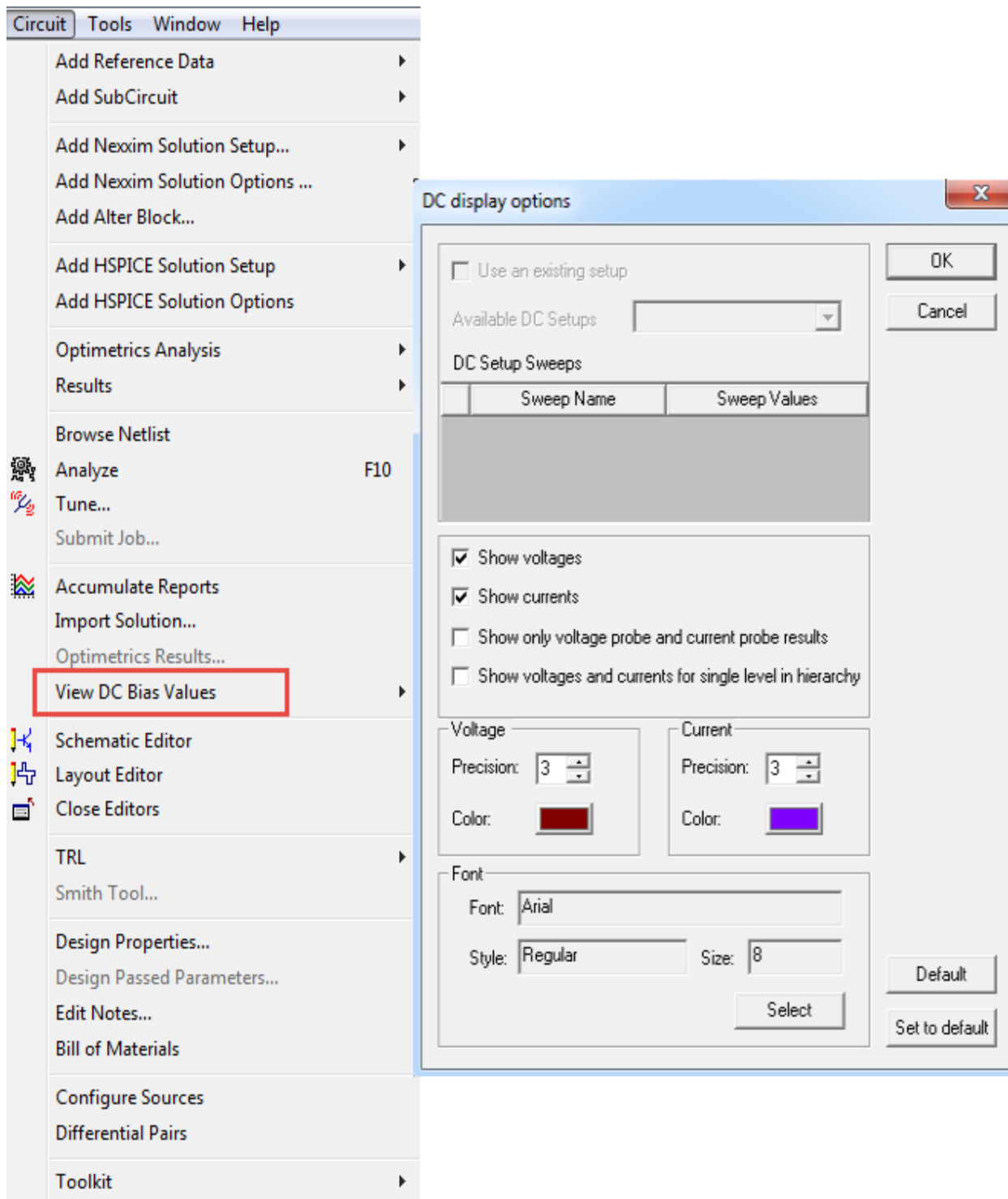

3 - LNA with Non-Linear Model

Non-linear model for the transistor using a SPICE library file in the circuit of the project LNA_RF_1_Tone_Start instead of an S-parameter data file.

Select the project **LNA_RF_1_Tone_Start.aedt** on the **Low Noise Amplifier** folder under **Examples > Circuit**.

Note: Caption boxes and oval shapes are added in the figure for clarity. These shapes do not appear in the actual design in **Electronics Desktop**.

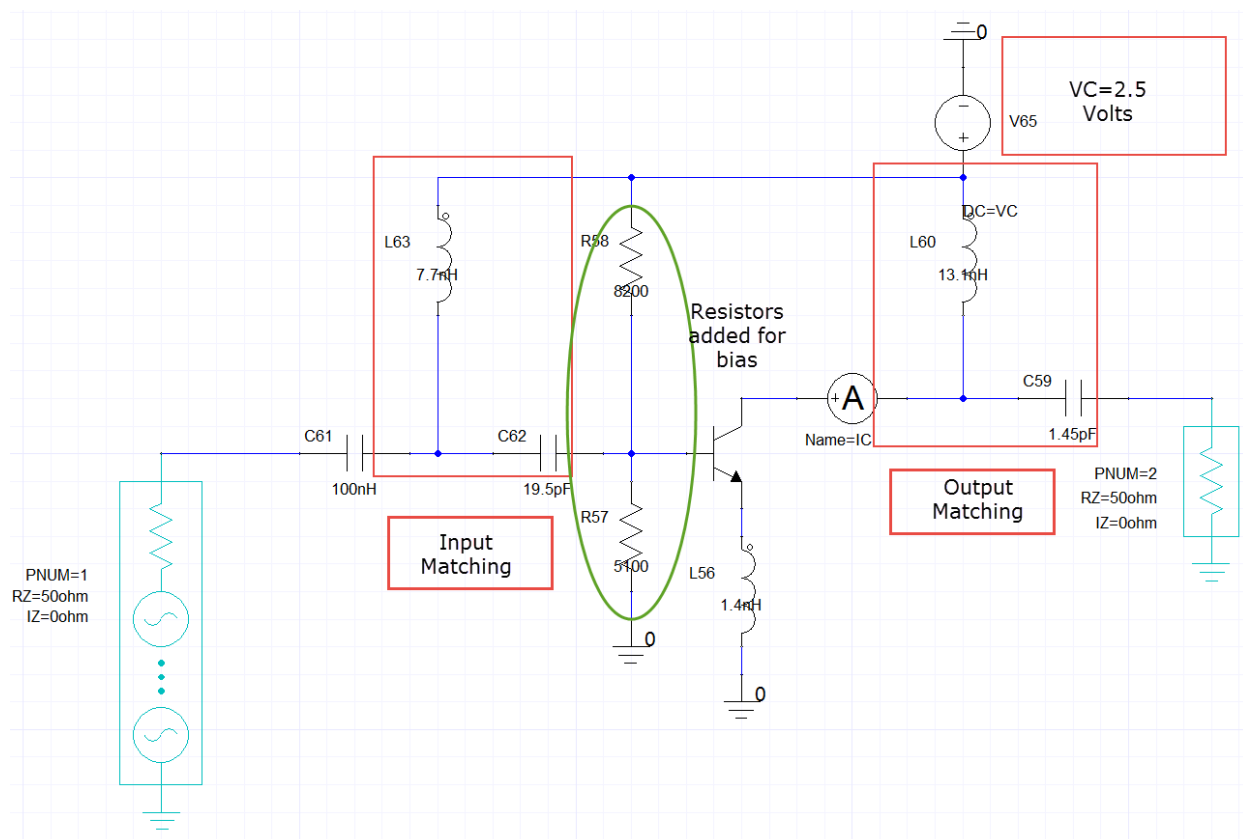

View DC Bias

The steps to view DC bias are as follows:

1. From the **Project Manager** window, right-click the **LNA_Matched_NL Project Tree** and select **View DC Bias Values>Show DC Bias** or the icon on toolbar.

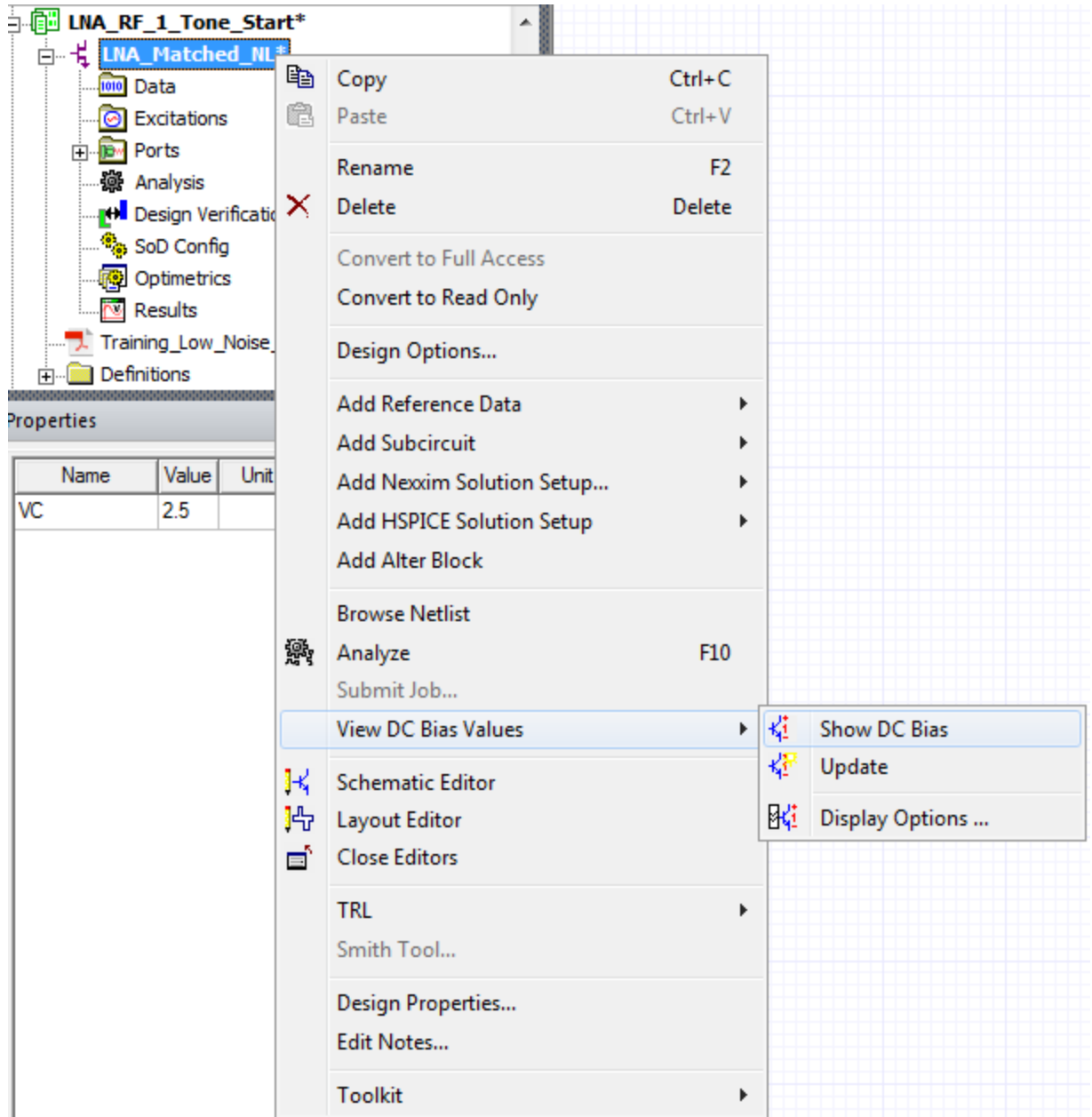

DC current and voltage at each node are displayed in the schematic as shown in the following figure. Select the **Show voltage** and **Show current** options on the **DC Display Options** window and click **Show DC Bias** in order to update the design with the corresponding values of the voltages on the nodes and currents through the branches.

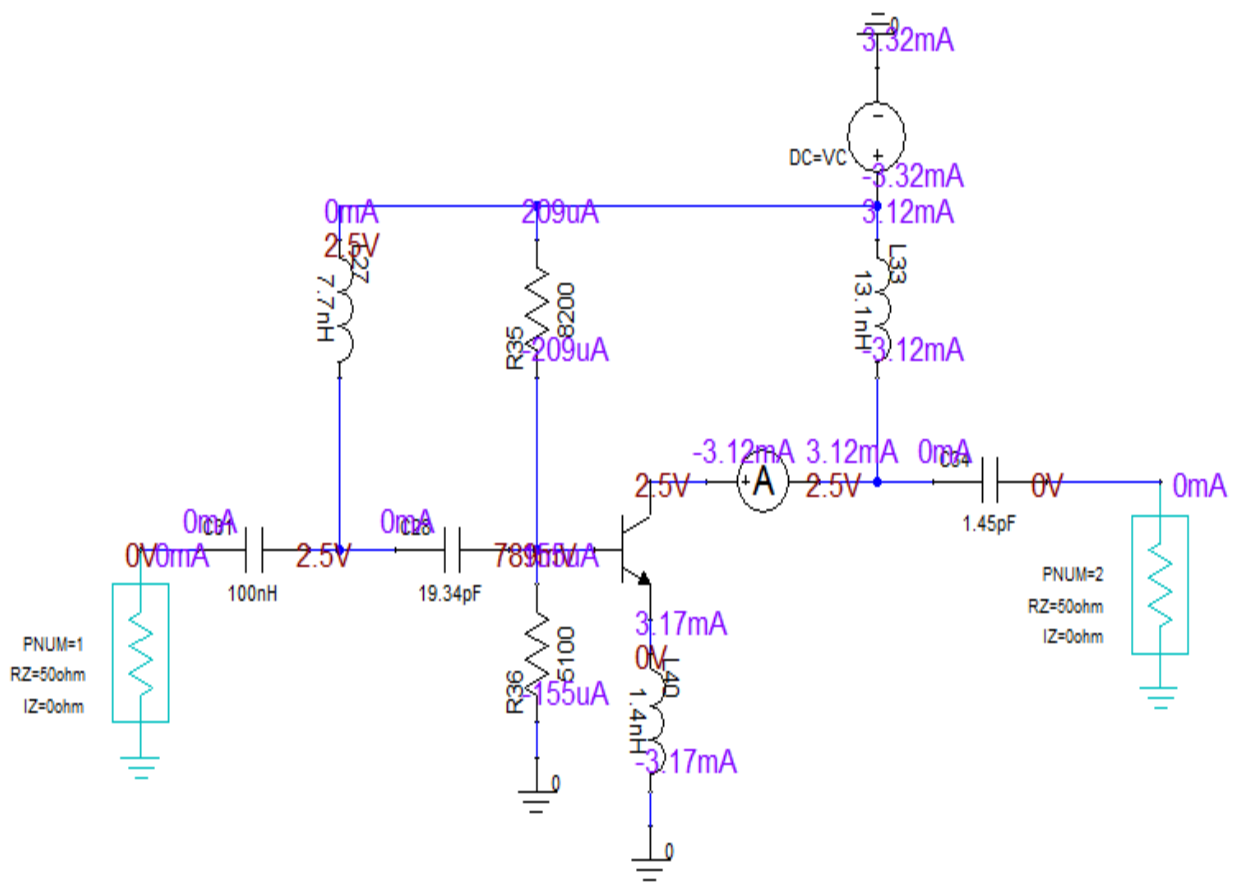

2. Check the bias of the transistor, with 2.5V, 3mA which was the bias point of the S parameters used for matching.
3. Save the project.

Run Linear Analysis

1. From the **Project Manager** window, expand the **Project Tree** and active design folder. Then right-click **Analysis** and select **Add Nexxim Solution Setup > Linear Network Analysis**.
2. Click Add and define a Linear Step sweep from 0.5 GHz to 2 GHz in steps of 0.01GHz.

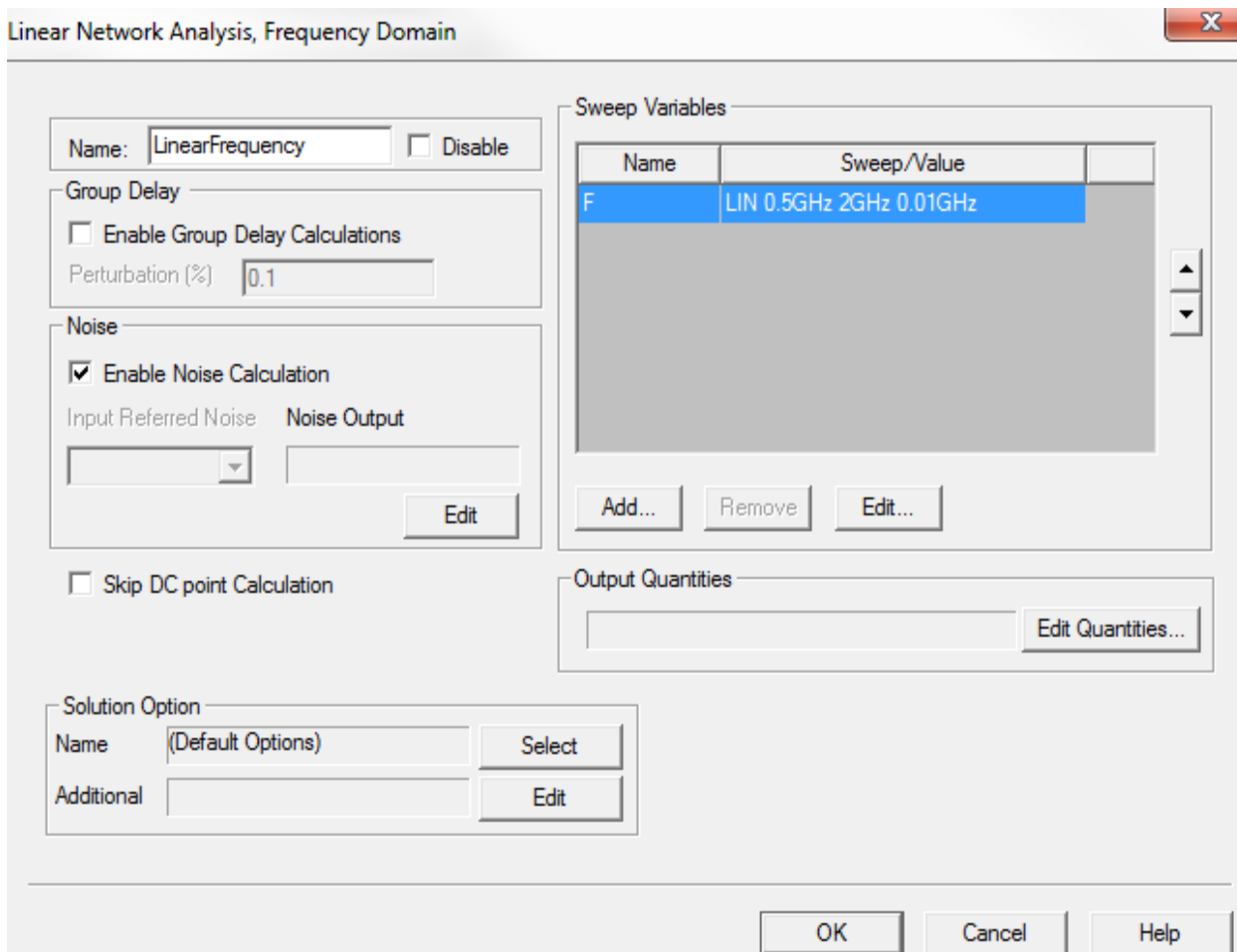

3. Select **Enable Noise Calculation** and click **OK**.
4. From the **Project Manager** window, expand **Project Tree** > active design folder > **Results**. Then right-click **LinearFrequency** to start simulation.

Create Report

1. From the **Project Manager** window, expand the **Project Tree** and active design folder. Then right-click **Results** and select **Create Standard Report** > **Rectangular Plot**: dBS21, dBS11, dBS22, and NF in dB.

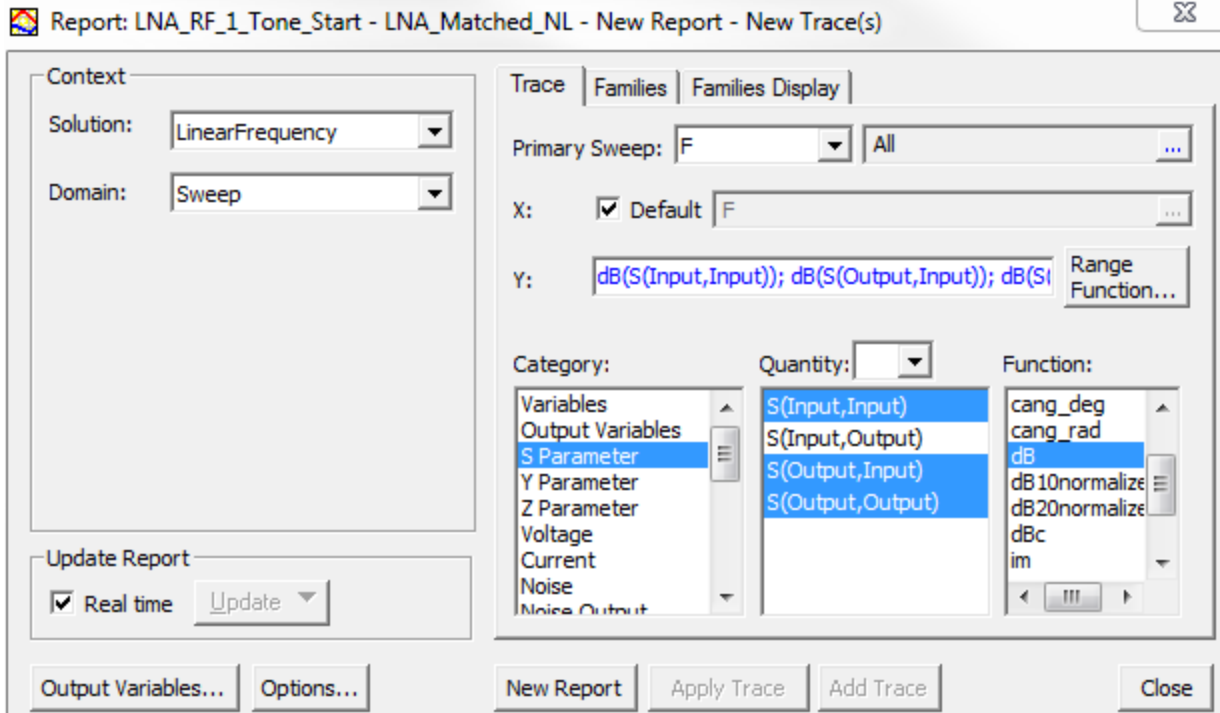

2. After selecting the options shown in Figure 15, click **New Report** to create the S-parameter plot.
3. Select Noise figure as shown in the following figure and click **Add Trace** and **Close**.
4. Rename the report to S Parameters & NF.

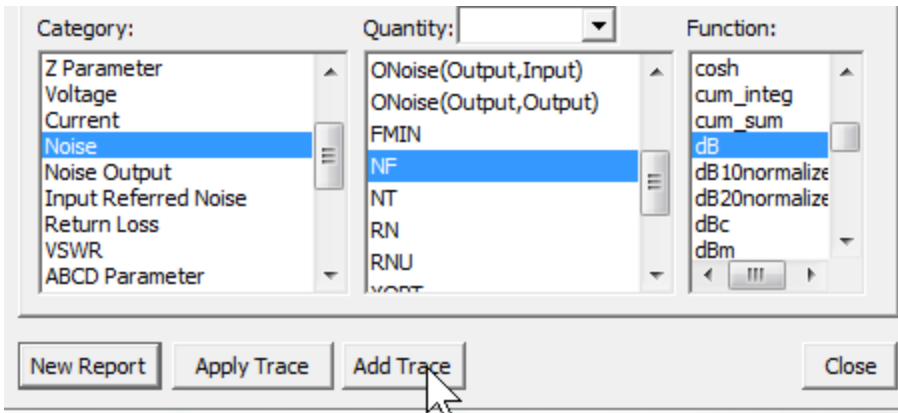

Using the non linear model, it is possible to run a linear analysis.

The non linear model is linearized at the bias condition and the simulation computes the corresponding small signal S parameters. This allows the user to check that the results using the non linear model are close to those obtained with the S parameter data file

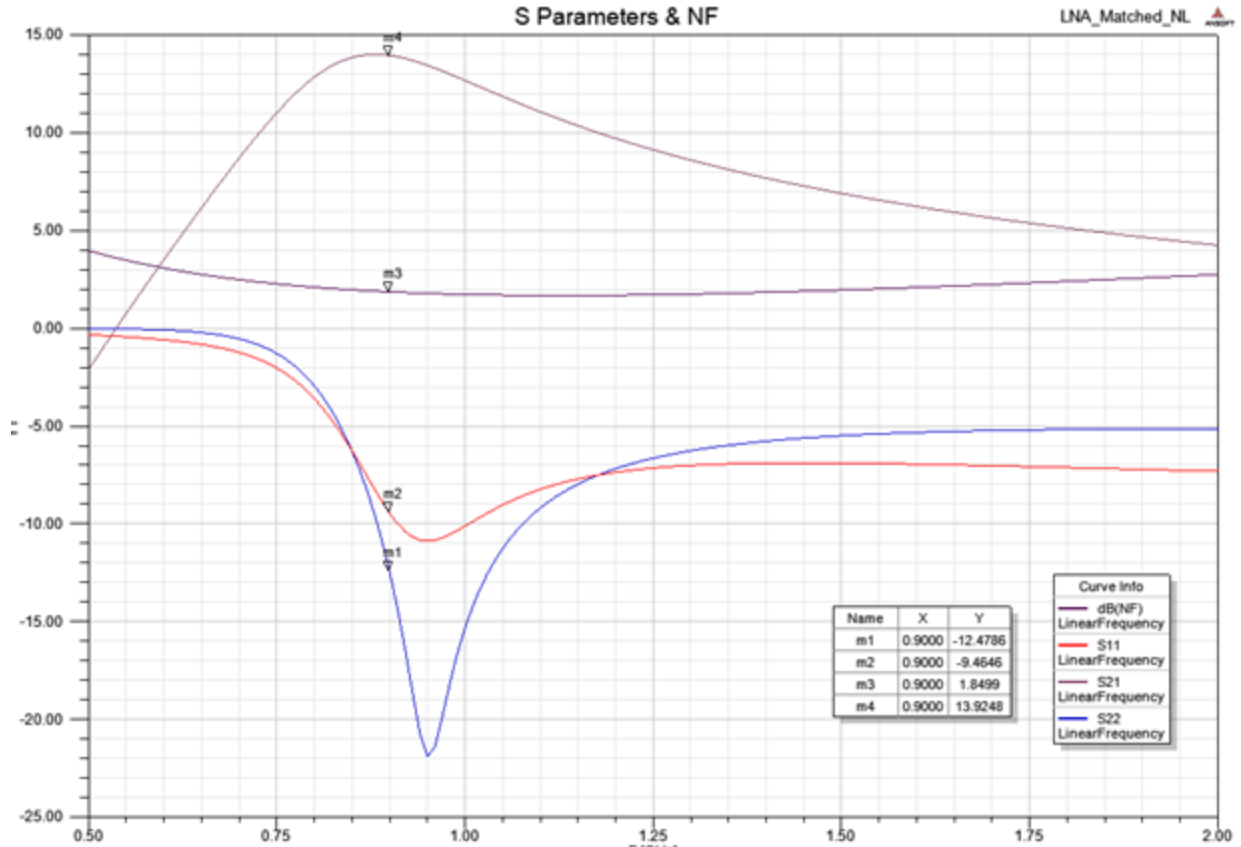

RF 1 Tone Nonlinear Analysis

1. Double-click the input port symbol to open the **Port Definition** window.

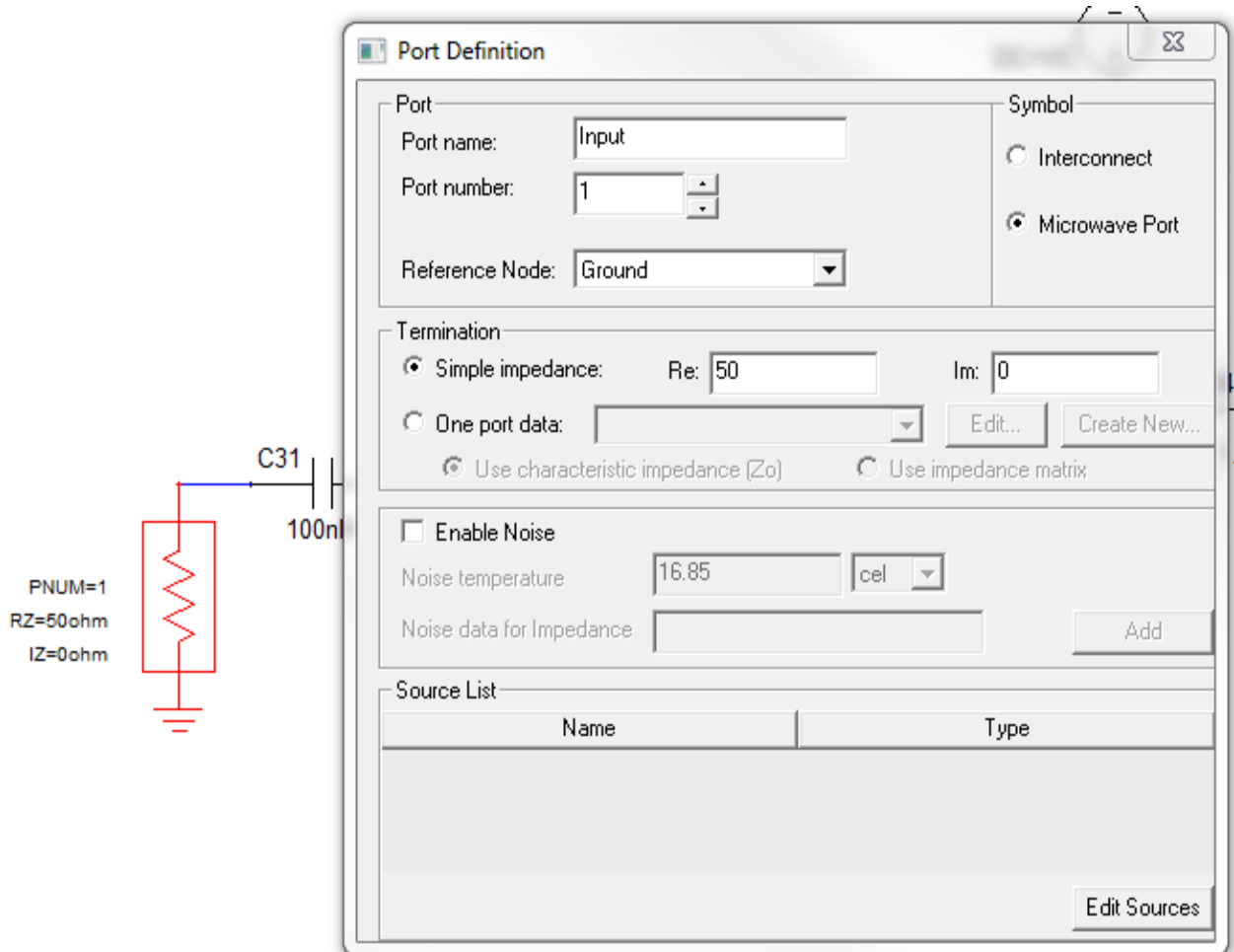

2. Click **Edit Sources** to open the **Configure Ports and Sources** window.
3. Ensure that **Input** is selected under **Ports List** and **Power** and **Sinusoidal** are selected under **Add New Source**.

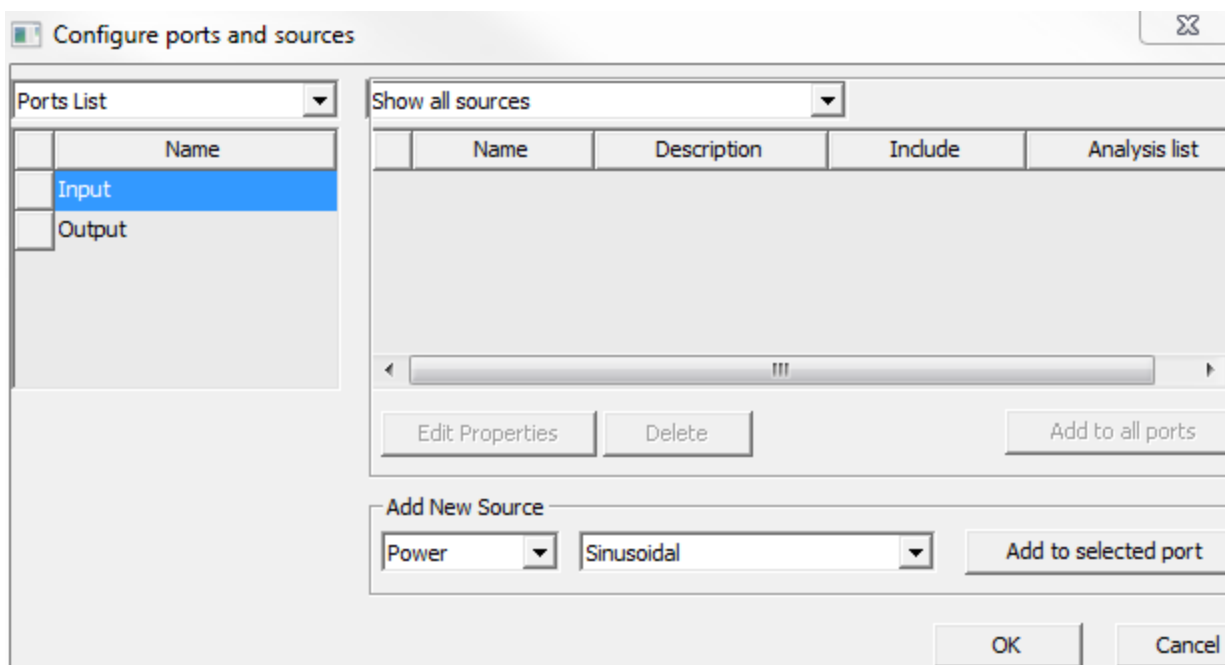

4. Click **Add to selected port** and edit Name to RF_IN .
5. Select Property POWER and enter Pin (local variable, -10dBm) as the value of property POWER.
 - In the **Add Variable** window, type -10dbm in the **Value** field and press **Enter**.
6. Select Property FREQ and enter F_IN (local variable, 0.9GHz) as the value of property FREQ.
 - In the **Add Variable** window, type 0.9GHz in the **Value** field and press **Enter**.

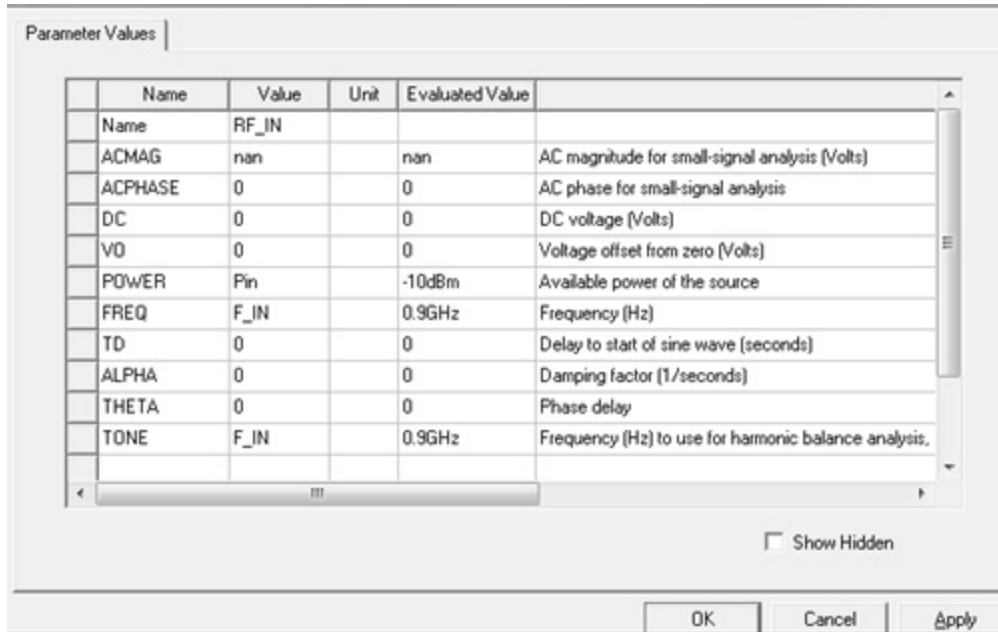

7. Select Property TONE and enter F_IN as the value of Property TONE and click **OK**.

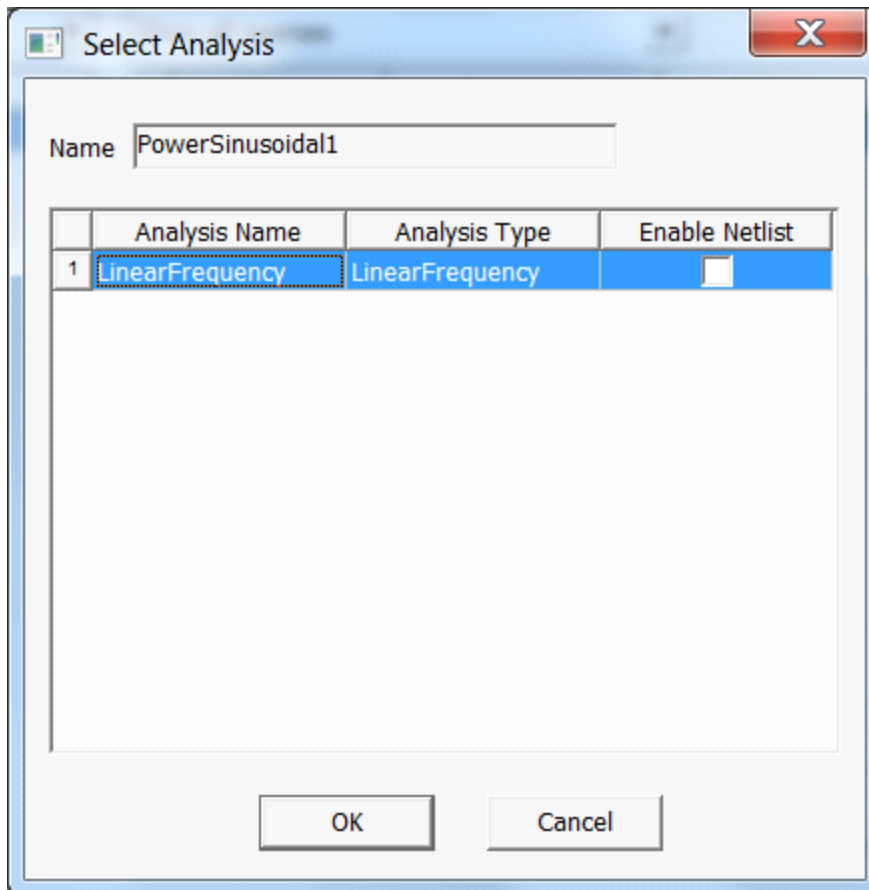

- Review the Configure and Port window to ensure that the final settings resemble those shown in the following figure.

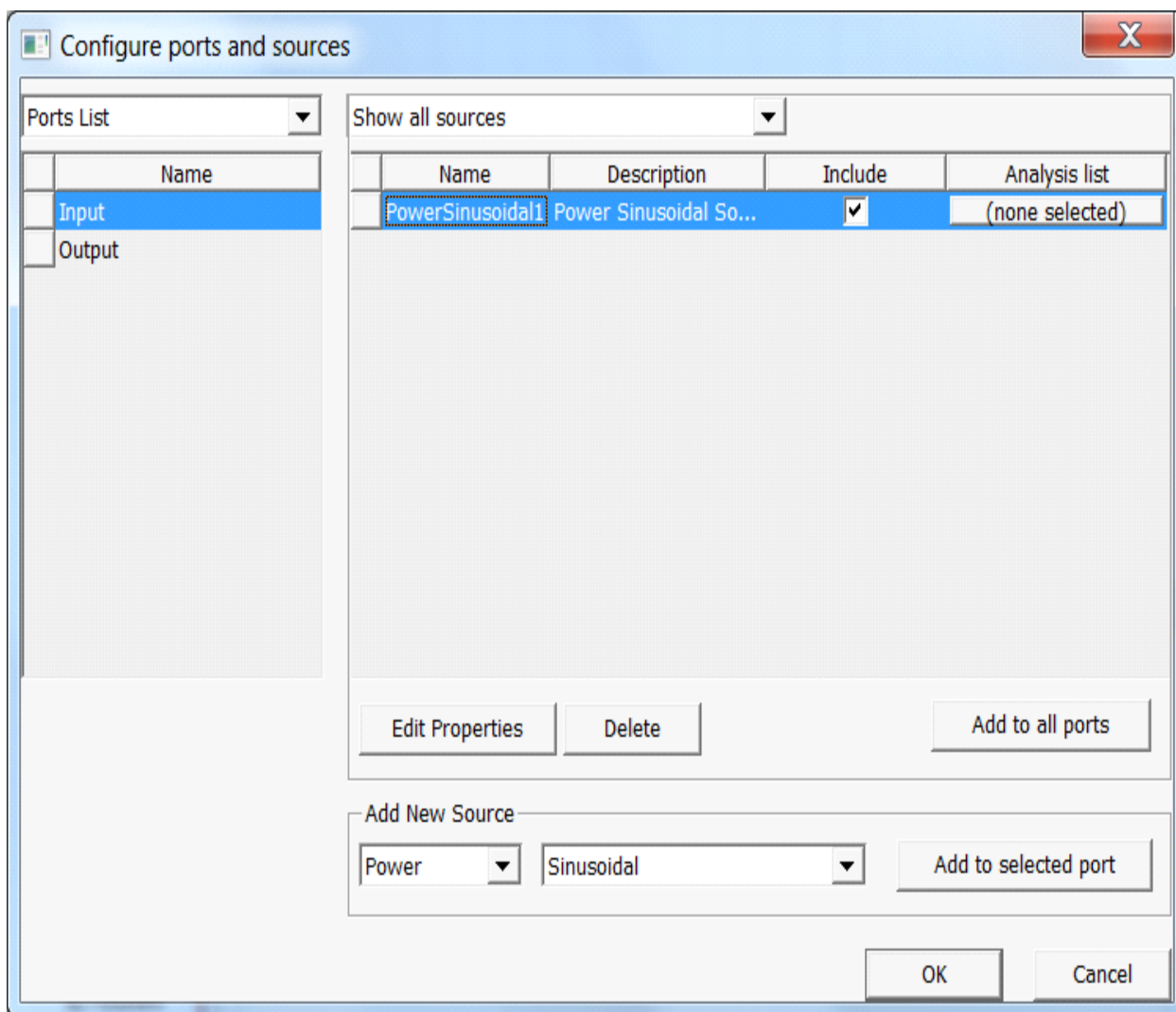

- Click **OK**.

Define RF 1 Tone Analysis

The **Select Analysis** window allows the user to match specific Sources (e.g., Power Sources, Voltage Sources) with specific **Analysis** setups. This offers the flexibility to have multiple **Sources** and multiple **Analysis** setups, then match them accordingly. Click **OK** to continue.

From the **Project Manager** window, window expand the **Excitations** option to verify that the source **RF_IN** is added. Notice that the schematic symbol for the input port has a different appearance indicating that a source is present.

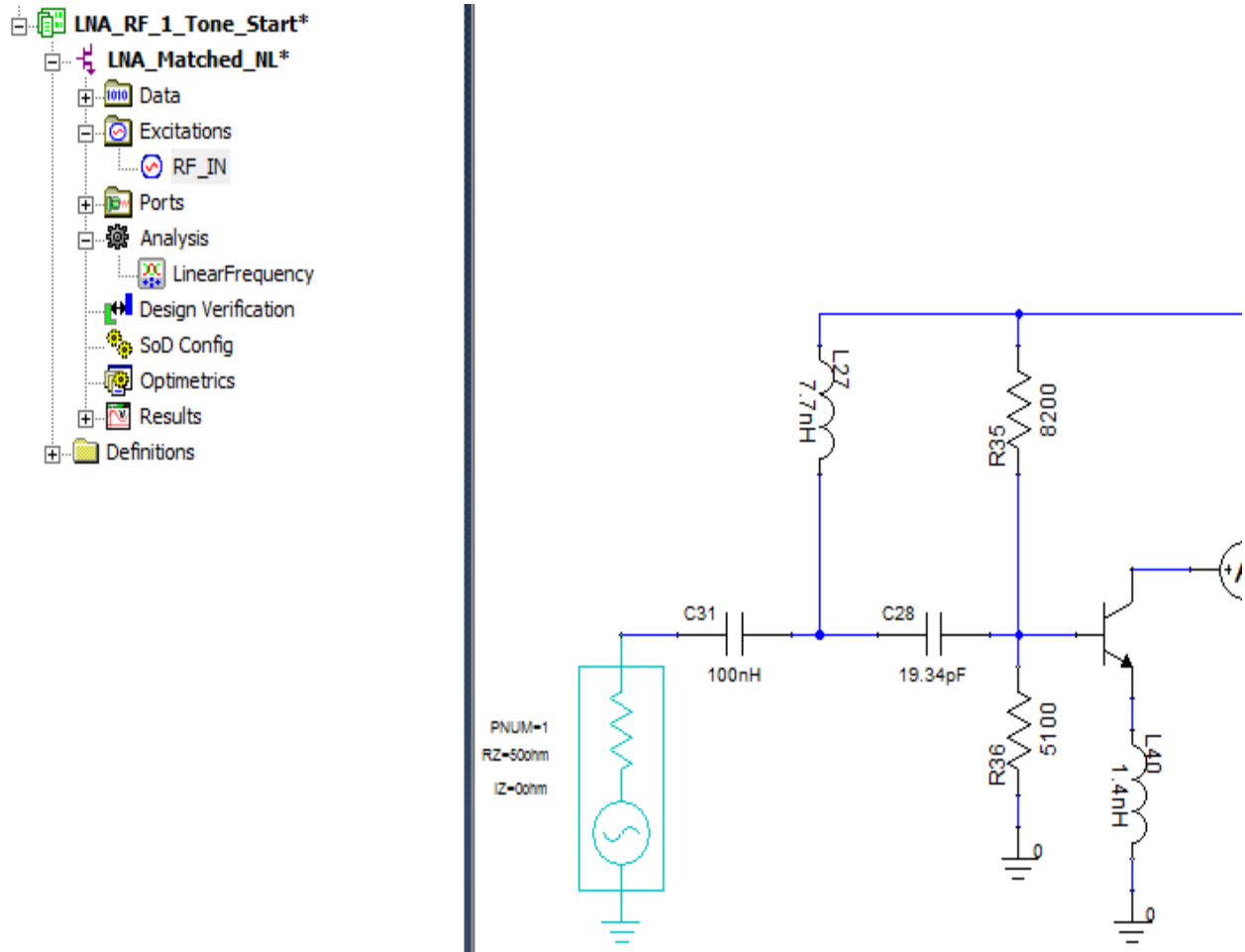

Define a Power Sweep and Analyze

1. From the **Project Manager** window, expand the **Project Tree** and active design folder. Then right-click **Analysis** and select **Add Nexxim Solution Setup ... > Harmonic Balance (1-Tone)** to open the **Harmonic Balance Analysis** window.

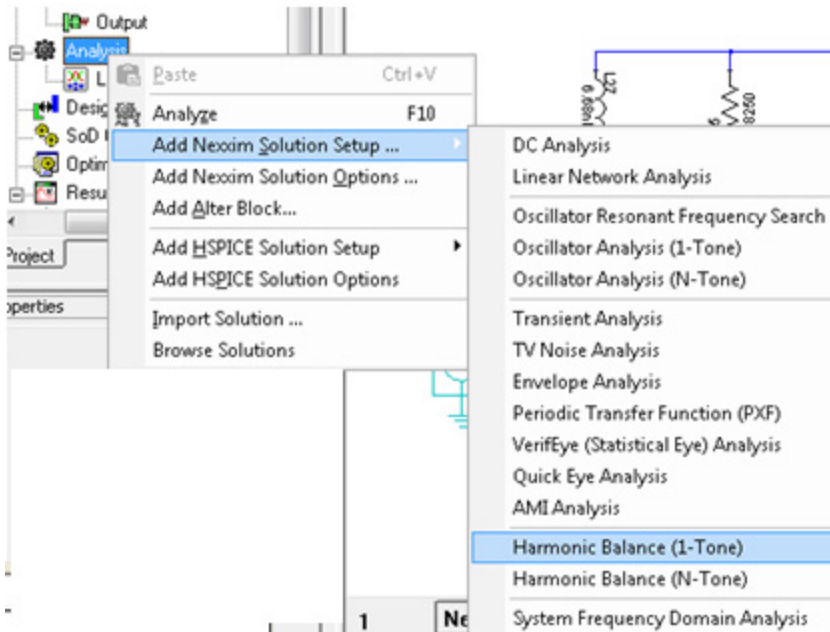

Harmonic Balance Analysis, 1-Tone

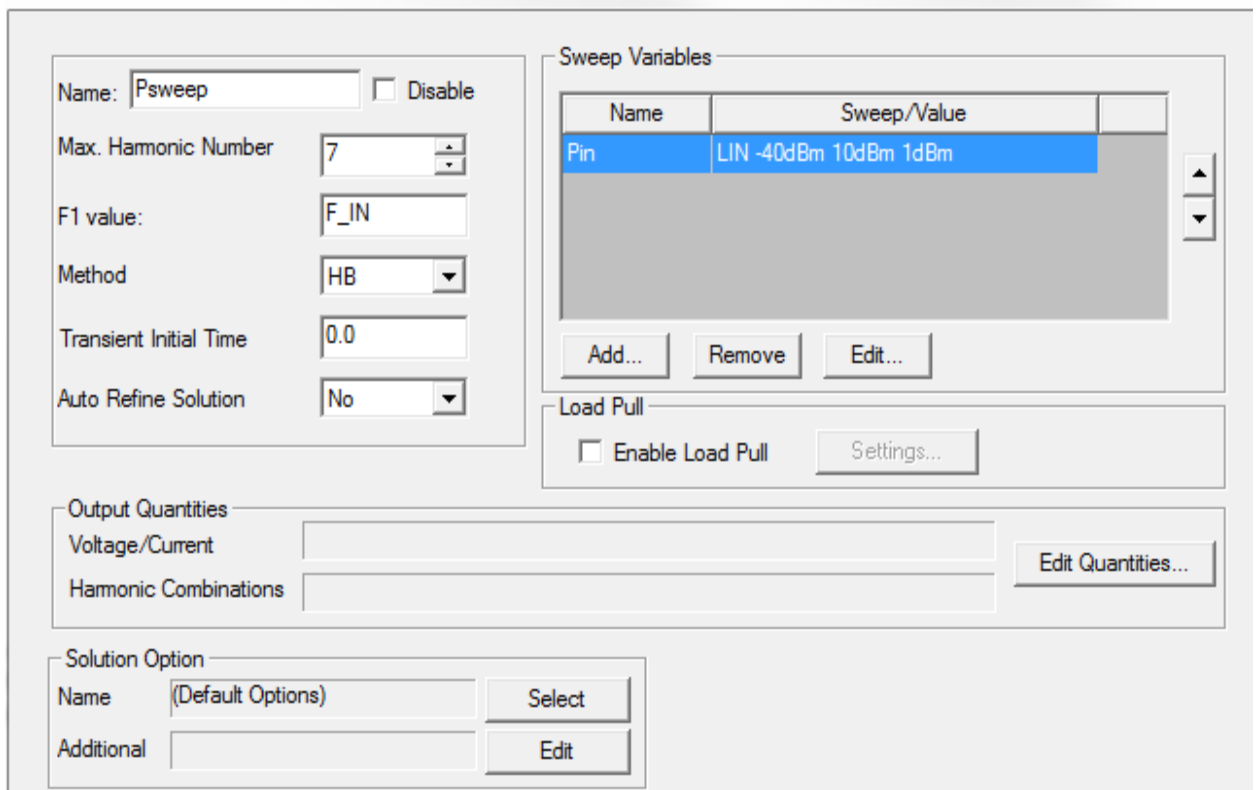

2. Enter the following settings:

- Name = *Psweep*.
 - Max. Harmonic Number = 7.
 - F1 value = F_{IN} .
3. In the **Sweep Variables** group box, click **Add** and select *Pin* on the **Variable** drop-down menu and set Linear Step from -40 dBm to 10 dBm in steps of 1 dBm.

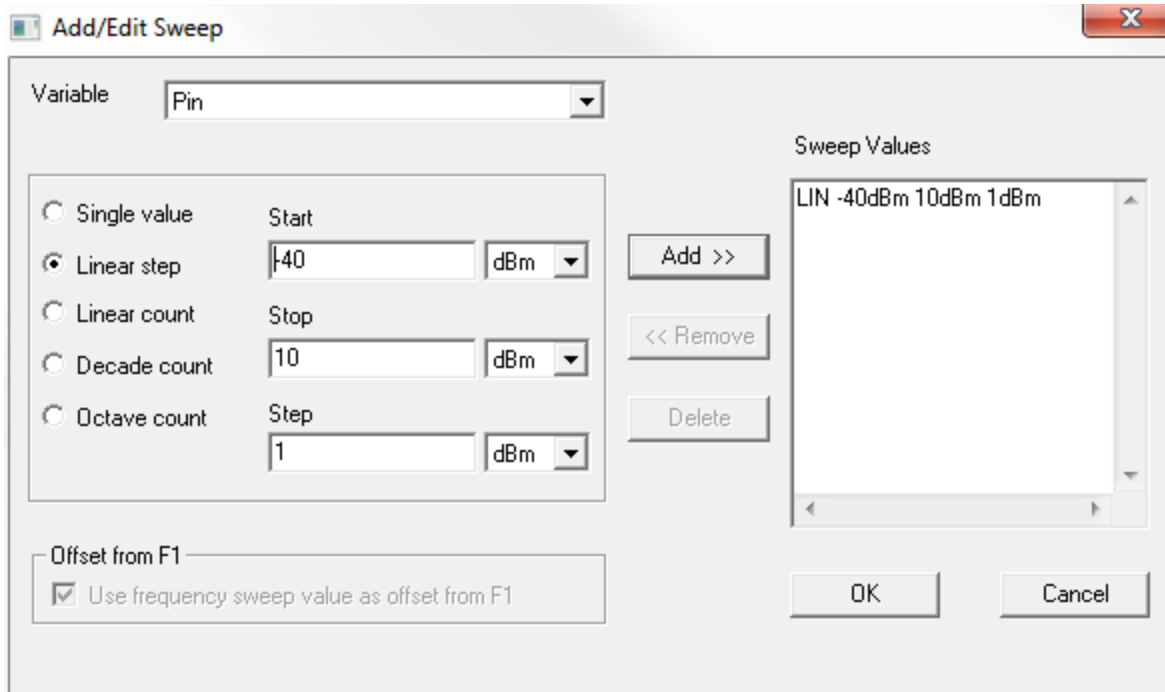

4. Click **Add** and accept the settings by clicking **OK**.
5. Expand **Analysis** and right-click **Psweep**. Then select **Analyze** to start simulation.

Create Results: Pout/TG21 vs. Pin

1. From the **Project Manager** window, expand the **Project Tree** and active design folder. Then right-click **Results** and select **Create Standard Report > Rectangular Plot**.
2. Select *Psweep* in the Solution field and *Sweep* in the Domain field.
3. Select Power, $P(\text{Output})\langle F1 \rangle$, dBm to plot the output power at Port 2 for the fundamental F1 and click New Report.

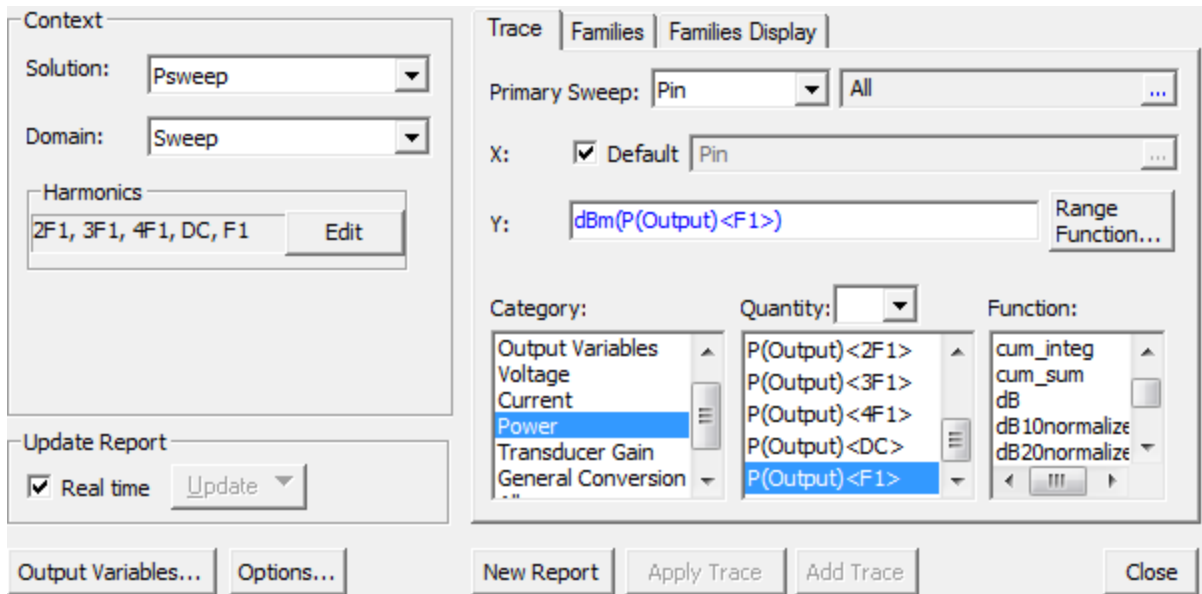

4. Select Transducer Gain, $TG(\text{Output, Input})\langle F1, F1 \rangle$, dB to plot the transducer gain between fundamental at port1 and fundamental at port2.
5. Click **Add Trace** and close the window.
6. From the **Project Manager** window, click Pout trace and in the Properties window set Y axis to Y2.

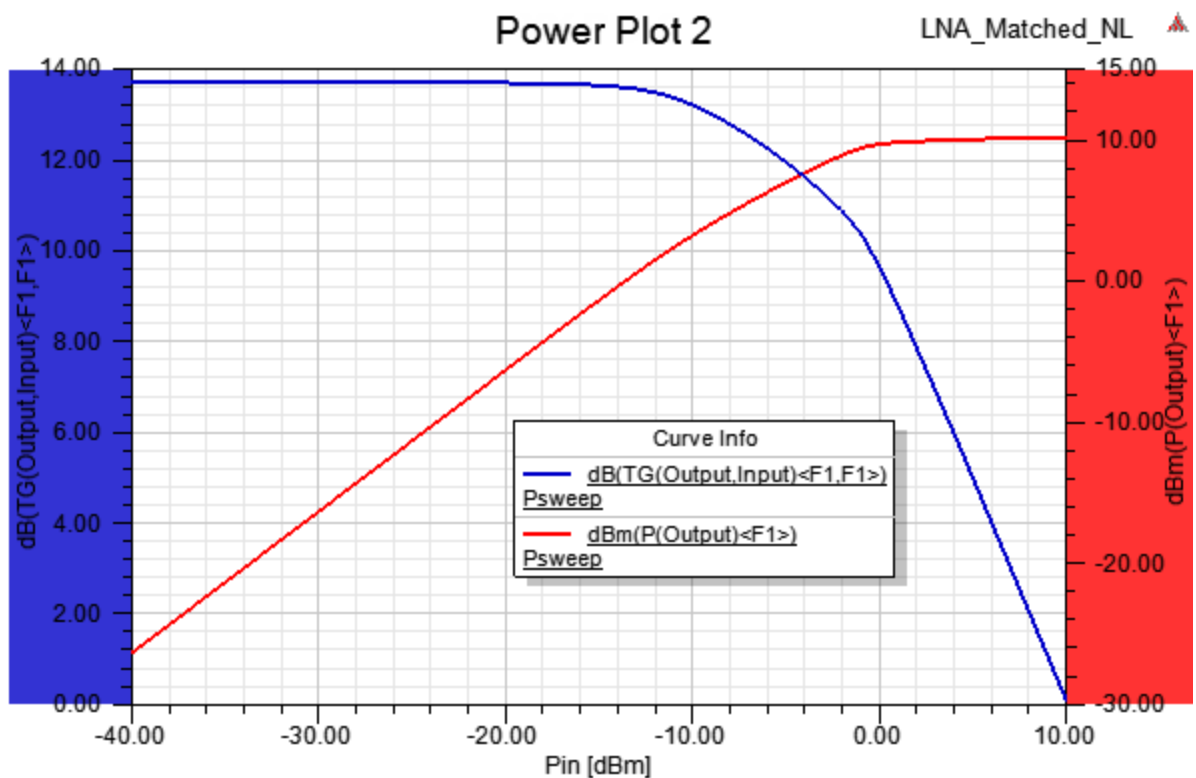

Create Results: Spectrum

1. Right+Click Results and select Create Standard Report/Rectangular Plot.
2. Select *PSweep* in Solution field and *Spectral* in the Domain field.
3. Select Power P(Output) in dBm and from the Families tab set variable Pin to *-15dBm*.
4. Click New Report and Close.
5. Rename the plot to **Pout Spectrum**.

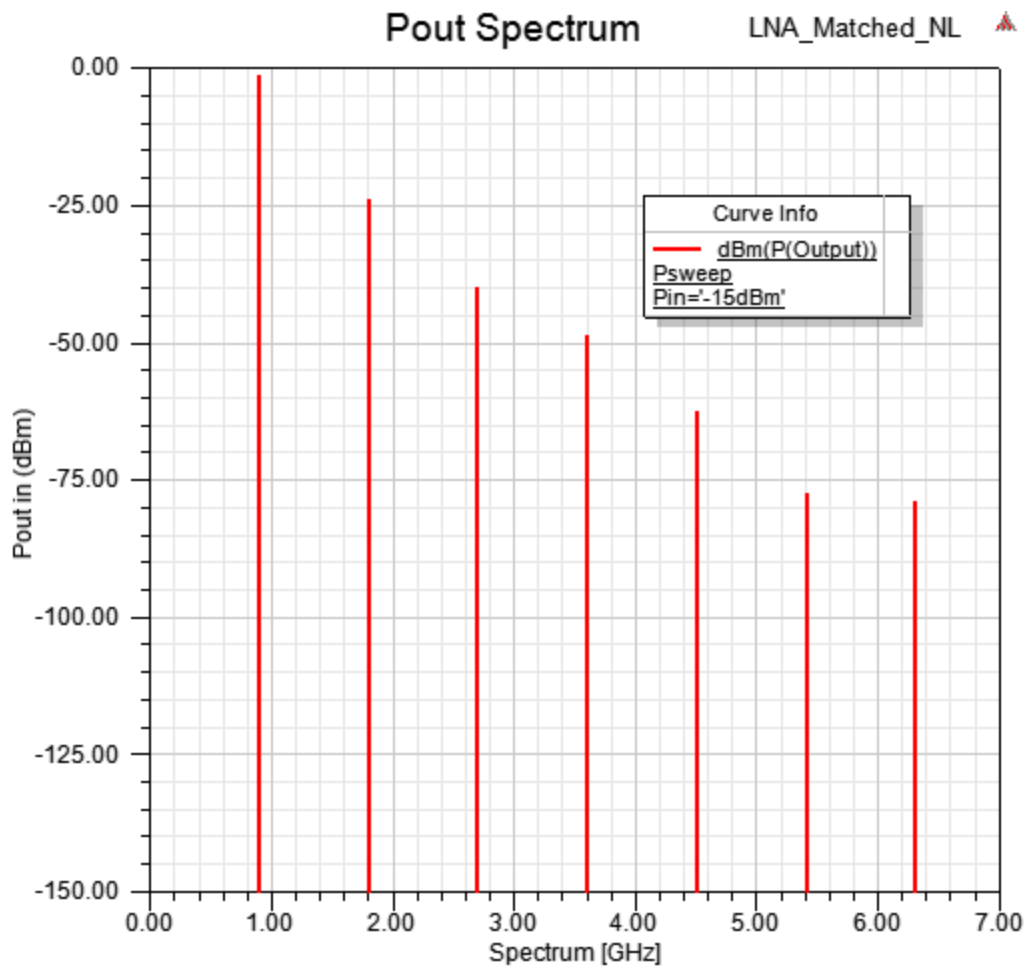

Create Results: Wave Form

1. From the **Project Manager** window, expand the **Project Tree** and active design folder. Then right-click **Results** and select **Create Standard Report/Rectangular Plot**.
2. Select *PSweep* on the Solution drop-down menu and *Time* in Domain field.
3. Select Category: *Voltage*, Quantity: *V(Output)*, Function: *none*

4. In the Families tab, for variable Pin, click **Edit** and select Pin = -40, -30, -20, -10 dBm for the Pin values. Click to close the window.
5. Click **New Report** and **Close**.

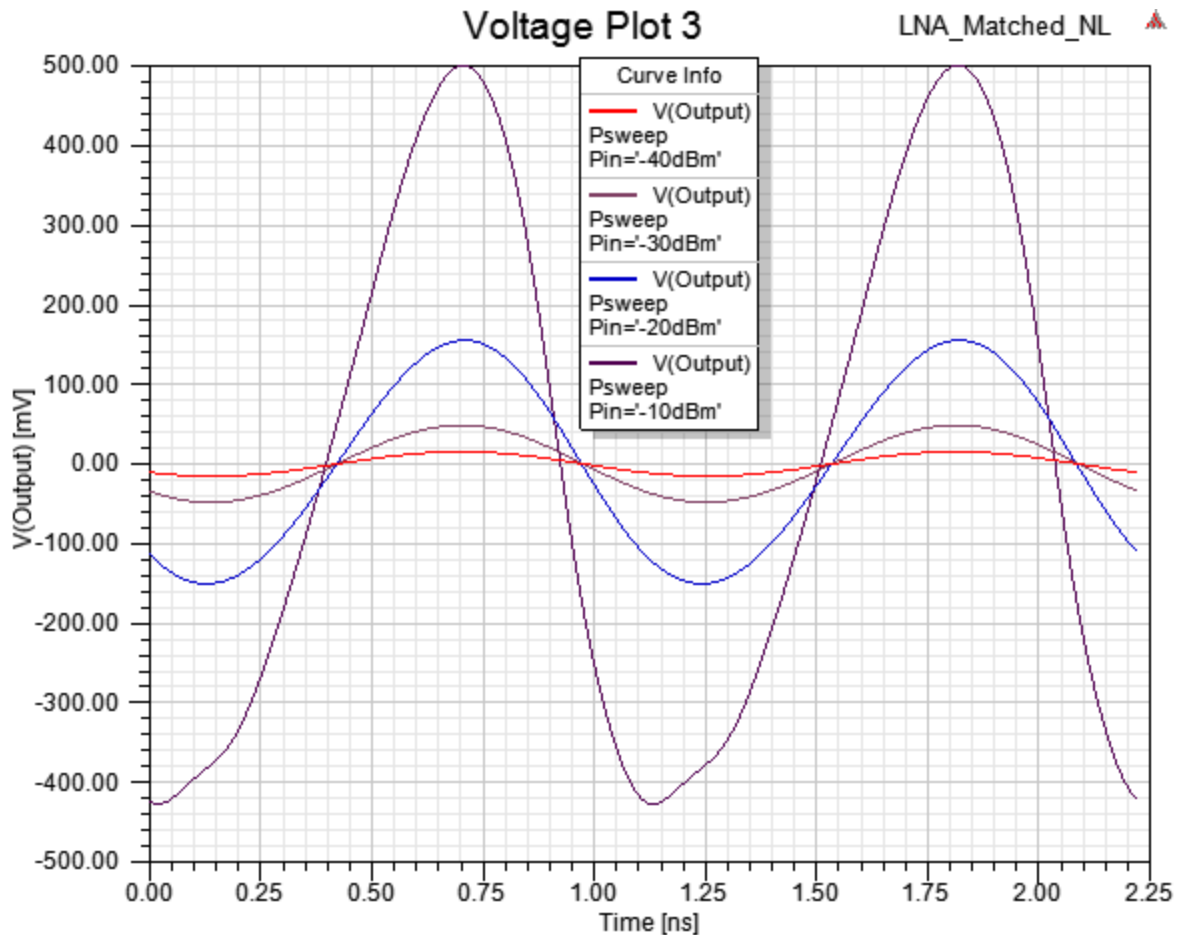

Add a Second RF Source to Input port

1. Double-click the input port symbol to open the **Port Definition** window.

Notice that the *RF_IN* power source is already present in the Source List group box as shown in the following figure.

2. Click **Edit Sources** to open the **Configure Ports and Sources** window.
3. Check that the “Input” port is selected under “Name” in the Port group box and in the “Add New Source” area ensure “Power” and “Sinusoidal” are selected.
4. Click **Add to selected port** and edit Name to *RF_IN2*.
5. Select Property **POWER** and enter Pin (recall the Pin variable was created earlier).

6. Select Property **FREQ** and enter F_IN2 (*local variable, 901MHz*) as the value of property **FREQ**.
7. In the **Add Variable** window type 901MHz in the **Value** field and press **Enter**.
8. Select Property **TONE** and enter F_IN2 as the value of property **TONE**.
9. Click **OK** to bring up the **Select Analysis** window.

The **Select Analysis** window allows you to match specific Sources (e.g., Power Sources, Voltage Sources) with specific Analysis Setups. This gives you the flexibility to have multiple Sources and multiple Analysis Setups, then match them accordingly.

The **Configure ports and sources** window should look as shown in the following figure.

Notice that the schematic symbol for the input port now has a different appearance indicating that 2 Sources are present.

Add Intermodulation Analysis Setup and Analyze

1. From the **Project Manager** window, expand the **Project Tree** and active design folder. Then right-click **Analysis** and select **Add Nexxim Solution Setup > Harmonic Balance (N-Tone)**.
2. Enter the following settings:
 - Set Name as InterMod
 - Click **Edit Tones/Maxk** and set **No. of Tones** to 2
 - Set **F1** to F_IN and **F2** to F_IN2 , **MaxK=5** for both.
 - Click **OK**.
3. Click **Add** in the **Sweep Variables** area and set **Linear Step** from -40 dBm to 0 dBm in steps of 1dBm for the variable **Pin**.
4. Click **Add > OK**.

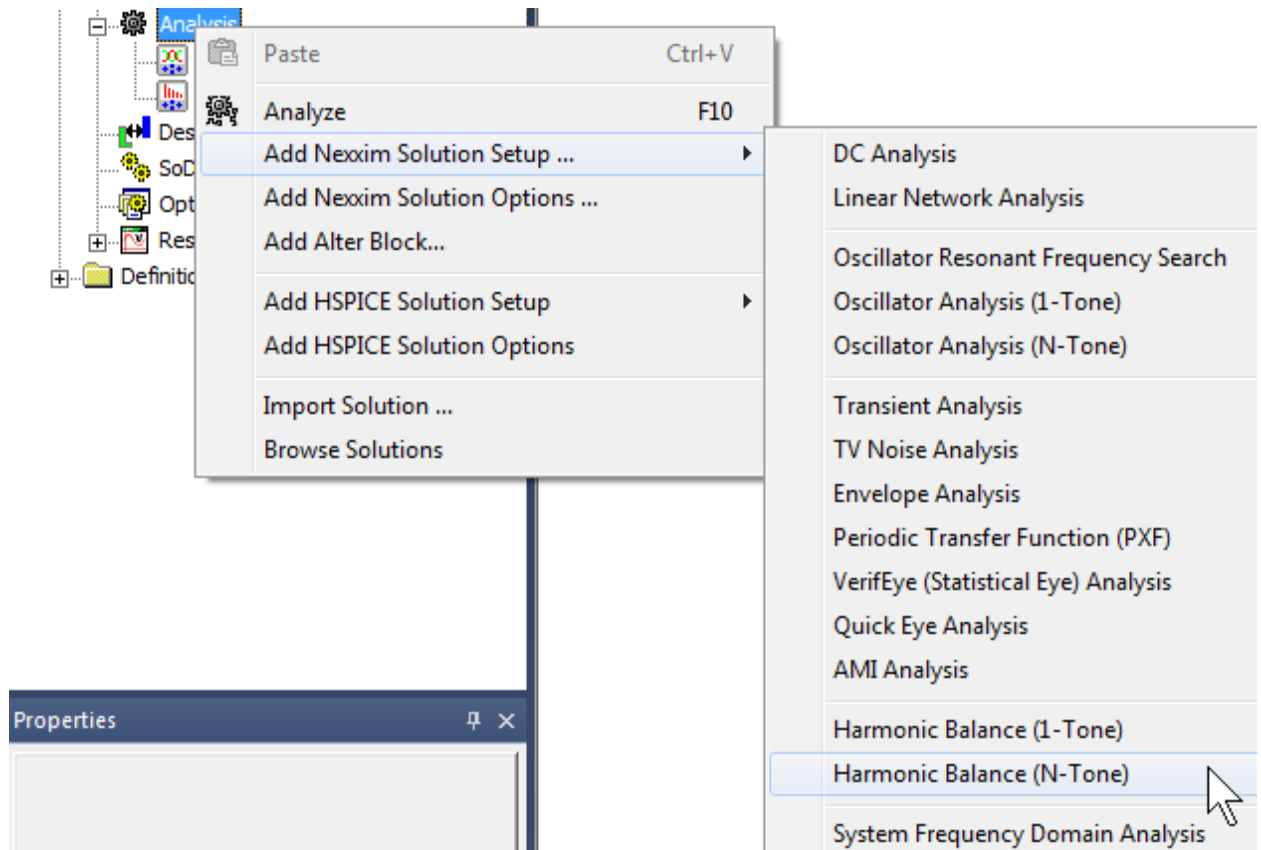

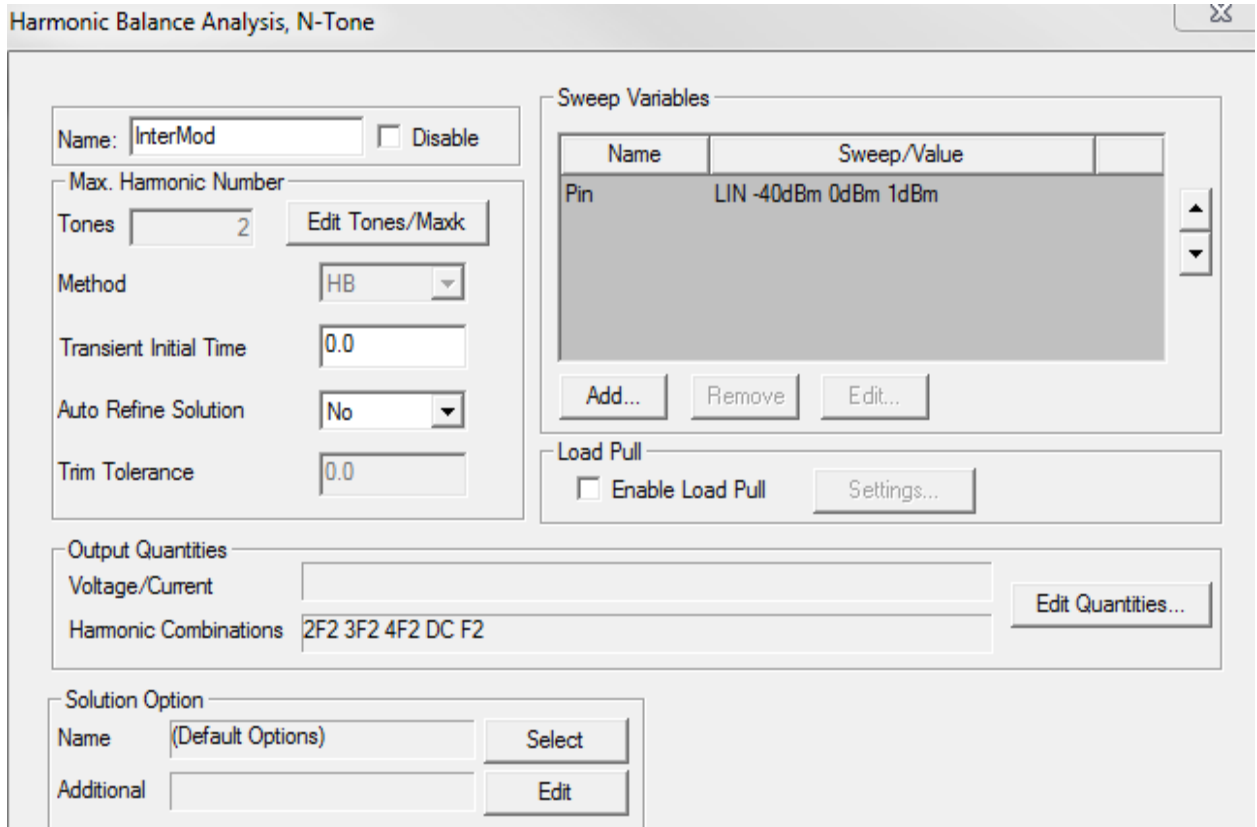

- Under **Analysis**, right-click **InterMod** and select **Analyze** to start the simulation.

Create Results: Pout vs Pin

- From the **Project Manager** window, expand the **Project Tree** and active design folder. Then right-click **Results** and select **Create Standard Report > Rectangular Plot** to open the **Report** window.
- Select **InterMod** on the drop-down **Solution** field and **Spectral** on the **Domain** field.
- Click Edit under Harmonics and include $F1$ and $-F1+2F2$ as Defined Outputs.
- Select *Power, $P(\text{Output})\langle F1 \rangle$, dBm* and click **New Report** to plot the output power at Output port for the fundamental.
- Select *Power, $P(\text{Output})\langle -F1+2F2 \rangle$, dBm*, click Add Trace to plot the output power at Output port for the *IM3*.
- Click Close.
- Rename the plot to **Pout vs pin InterMod**.

See the difference in slopes between the fundamental and third order products. As expected, the third order term has a slope that is 3 times unity in linear region.

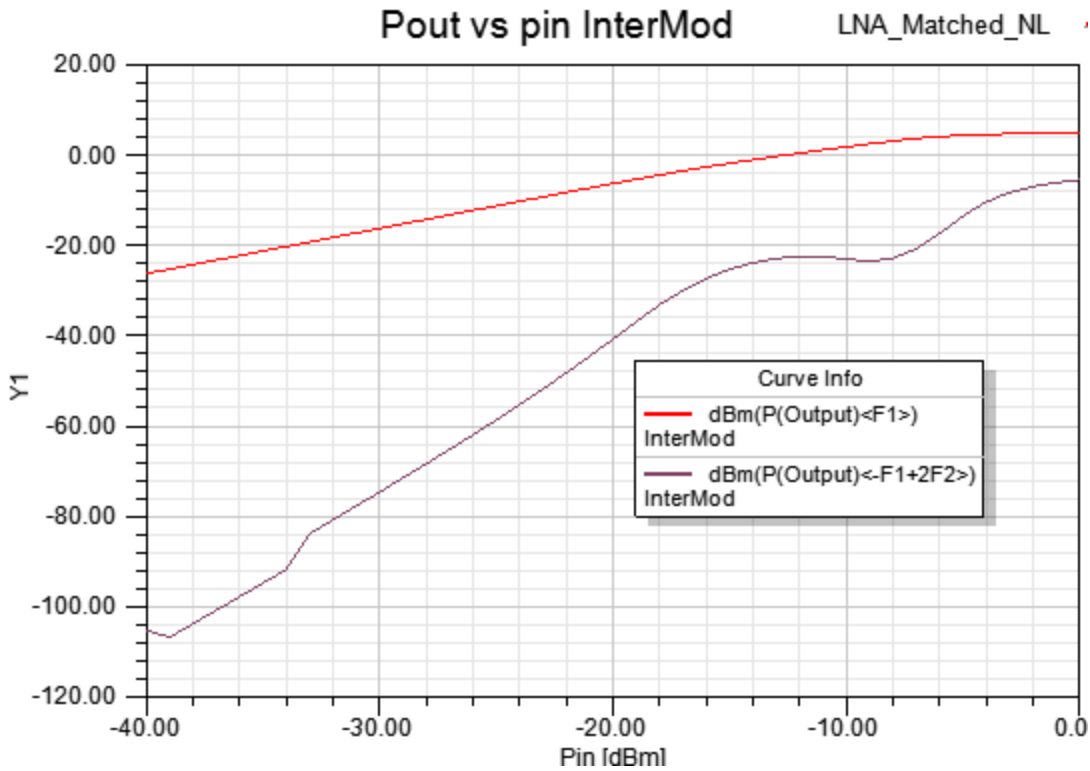

Create Results: Calculate IP3

1. From the **Project Manager** window, expand the **Project Tree** and active design folder. Then right-click **Results** and select **Create Standard Report > Data Table**.
2. Select **InterMod** in Solution field and **Sweep** in domain field.
3. Click **Output Variables ...** to open the Output Variables window.
4. Enter in the expression field :

$$\text{dBm}(P(\text{Output})\langle F1\rangle) + (\text{dBm}(P(\text{Output})\langle F1\rangle) - \text{dBm}(P(\text{Output})\langle -F1+2F2\rangle)) / 2$$

5. Enter in field Name: **IP3**, and click **Add** and **Done**.
6. Select **Output Variable** in Category, **IP3** in Quantity *None* as Function, and in Primary Sweep select Pin value = -34dBm.
7. Click **New Report** and **Close**.

	Pin [dBm]	IP3 InterMod
1	-34.000000	15.353886

Create Results: Intermodulation Spectrum

1. From the **Project Manager** window, expand the **Project Tree** and active design folder. Then right-click **Results** and select **Create Standard Report > Rectangular Plot** to open the **Report** window.
2. Select **InterMod** on the drop-down **Solution** field and **Spectral** on the **Domain** field.
2. From the Families tab, click **Edit**, select $P_{in} = -4$ dBm, and on the Traces tab, select Power, $P(\text{Output})$, dBm.
3. Click **New Report**, and click **Close**.
4. Rename the plot to **Intermodulation Spectrum**.

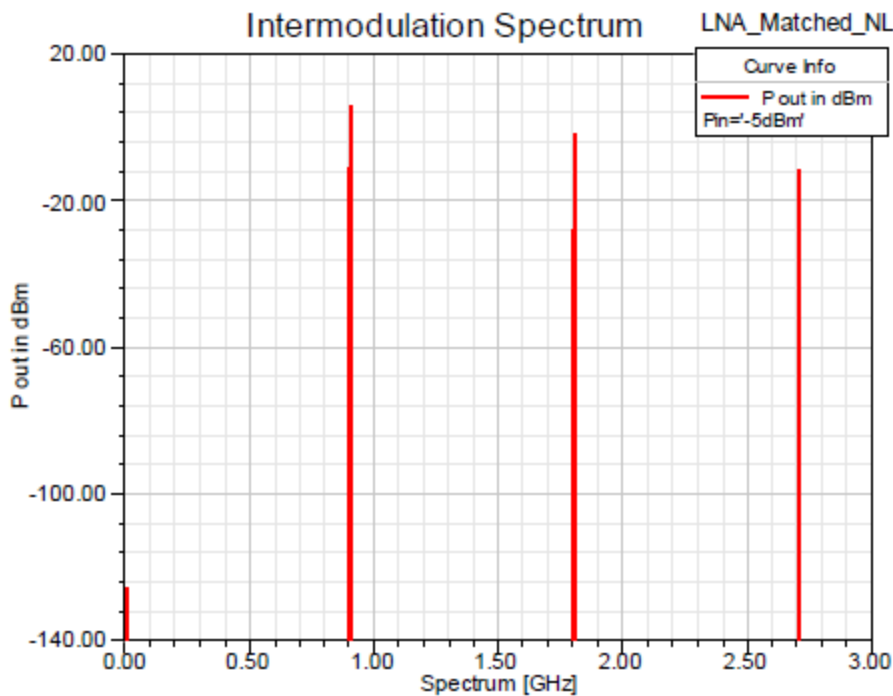

Harmonic Balance: Setup and Options

Harmonic Balance Analysis can be controlled using the options shown:

- Max Harmonic Number: Max harmonics computed in the solution (MAXK)
- F1 value is the single tone frequency, using a variable F_IN in this example.

The Method parameter selects between the standard harmonic balance calculation and a shooting method that facilitates single-tone analysis of circuits with strongly nonlinear behavior.

- Method=HB, standard harmonic balance, is the default for single-tone analysis and is always used for multi-tone harmonic balance analysis.

- Method=Shooting is available for single-tone analyses only. When method is set to shooting, single-tone harmonic balance uses a time-domain shooting method that is efficient for nonlinear circuits. This option is ignored for multi-tone harmonic balance.

Transient Initial Time set to a positive non-zero value is representing time required for Transient to stabilize before HB begins using the result.

With Auto_Refine_Solution=yes, Nexxim examines the result at each sweep iteration to determine if the solution is sufficiently resolved. If it is not, Nexxim doubles the number of harmonics and repeats the iteration. Thus, you can start the sweep with MAXK set to a low number, and have Nexxim automatically adjust MAXK as needed to maintain accuracy.